

Introduction
 Thank you for purchasing the UP550 program controller. The controller is shipped from the factory with 7 hardcopy user's manuals (A2 size) and 1 user's manual on CD-ROM. The 7 user's manuals in hardcopy format describe the operating procedures required for basic use (factory-set to single-loop control mode). It is recommended that you refer to these user's manuals to understand [1] installation, [2] initial settings, [3] program settings and [4] operating procedures of the controller. The CD-ROM contains an User's Manual (Reference) with descriptions of various functions and setting ranges that can be set as necessary. The manual also contains information on operations used to carry out control other than single-loop control. Moreover, the use of an optional parameter setting tool (model: LL100-E10) allows you to easily perform settings and adjustments with a PC.

Purpose	Manual Title	Description	Media
Setup	Installation	Describes the tasks (installation, wiring, and others) required to make the controller ready for operations.	A2-size paper, back and front
Basic operation	Initial Settings	Describes examples of setting PV input types and control output types. Making settings described herein and program creation in Programming User's Manual allows you to carry out basic control.	A2-size paper, back and front
Program creation	Programming	Describes examples of creating basic programs. The use of the program pattern setup charts included in the Program Parameters User's Manual is recommended.	A2-size paper, back and front
General understanding of programming operations	Program Parameters	Contains a parameter map that serves as a guide to creating programs. Also includes a brief explanation of the functions of program parameters.	A2-size paper, back and front
Operating procedures and troubleshooting	Operations	Describes key operation sequences. For operation control through external contact inputs, see the back of Installation User's Manual.	A2-size paper, back and front
Brief operation	Parameter Map	Contains the parameter map used as a guideline for setting parameters.	A2-size paper, back and front
Function description and setpoint recording	Parameters	Briefly describes the functions of parameters. In addition, each parameter table has a User Setting column, where you can record your setpoints when setting them in the controller.	A2-size paper, back and front
Detailed description of functions	User's Manual (Reference)	Explains more advanced applications than those found in the 7 hardcopy user's manuals (A2 size).	CD-ROM

1. Safety Precautions
 The following symbol is indicated on the controller to ensure safe use.
CAUTION
 This symbol on the controller indicates that the operator must refer to an explanation in the user's manual in order to avoid the risk of injury or death of personnel or damage to the instrument. The manual describes how the operator should exercise special care to avoid electric shock or other dangers that may result in injury or loss of life.

The following symbols are used in the hardcopy user's manuals and in the user's manual supplied on the CD-ROM.
NOTE
 Indicates that operating the hardware or software in a particular manner may damage it or result in a system failure.
IMPORTANT
 Draws attention to information that is essential for understanding the operation and/or features of the controller.

Exemption from Responsibility
 Make sure that all of the precautions are strictly adhered to. Yokogawa Electric Corporation assumes no liability for any damage resulting from use of the instrument in contradiction to the precautions. Also, Yokogawa Electric Corporation assumes no liability to any party for any loss or damage, direct or indirect, caused by the use of any unpredictable defect of the instrument.
Regarding Protection, Safety, and Prohibition Against Unauthorized Modification
 (1) In order to protect the product and the system controlled by it against damage and ensure its safe use, make certain that all of the instructions and precautions relating to safety contained in this document are strictly adhered to. Yokogawa does not guarantee safety if products are not handled according to these instructions.
 (2) Modification of the product is strictly prohibited.

2. Model and Suffix Codes
 Before using the controller, check that the model and suffix codes match your order.

Model	Suffix Code	Description
UP550		Program controller (provided with retransmission output and 15 VDC loop power supply as standard)
Type	-0	Standard type
	-1	Position proportional type
	-2	Heating/cooling type
Optional functions	0	None
	1	With communication, auxiliary analog input (Note), and 1 additional DI

Note: Not used in single-loop control.
 Check that the following items are provided:
 • Program controller (of ordered model): 1
 • Brackets (mounting hardware): 1 pair
 • Unit label: 1
 • User's Manuals for Single-loop Control: 7 (A2 size)
 • User's Manual (Reference) (CD-ROM Version): 1

Correspondence between the Model and Suffix Codes, and the Contact Input/Output Terminals Provided
 Check the model ordered and the presence/absence of contact inputs and outputs in the following table.
 ✓ indicate that the contacts are available.

Model and Suffix Codes	Contact input terminals								Contact output terminals						
	DI1	DI2	DI3	DI4	DI5	DI6	DI7	DI8	DO1	DO2	DO3	DO4	DO5	DO6	DO7
UP550-□0	✓	✓	✓	✓	✓	✓	✓	✓	✓	✓	✓	✓	✓	✓	✓
UP550-□1	✓	✓	✓	✓	✓	✓	✓	✓	✓	✓	✓	✓	✓	✓	✓

Note: For details on the functions of contact inputs/outputs, see "Terminal Wiring Diagrams" on the back of the manual.

3. How to Install
NOTE
 To install the controller, select a location where:
 (1) no one may accidentally touch the terminals,
 (2) mechanical vibrations are minimal,
 (3) corrosive gas is minimal,
 (4) temperature can be maintained at about 23°C and the fluctuation is minimal,
 (5) no direct radiant heat is present,
 (6) no magnetic disturbances are caused,
 (7) no wind blows against the terminal board (reference junction compensation element),
 (8) no water is splashed,
 (9) no flammable materials are around.

Never place the controller directly on flammable items or equipment. If the controller has to be installed close to flammable items or equipment, be sure to provide shielding panels all around the controller, at least 150mm away from every side; the panels should be made of either 1.43mm-thick metal-plated steel plates or 1.6mm-thick uncoated steel plates.

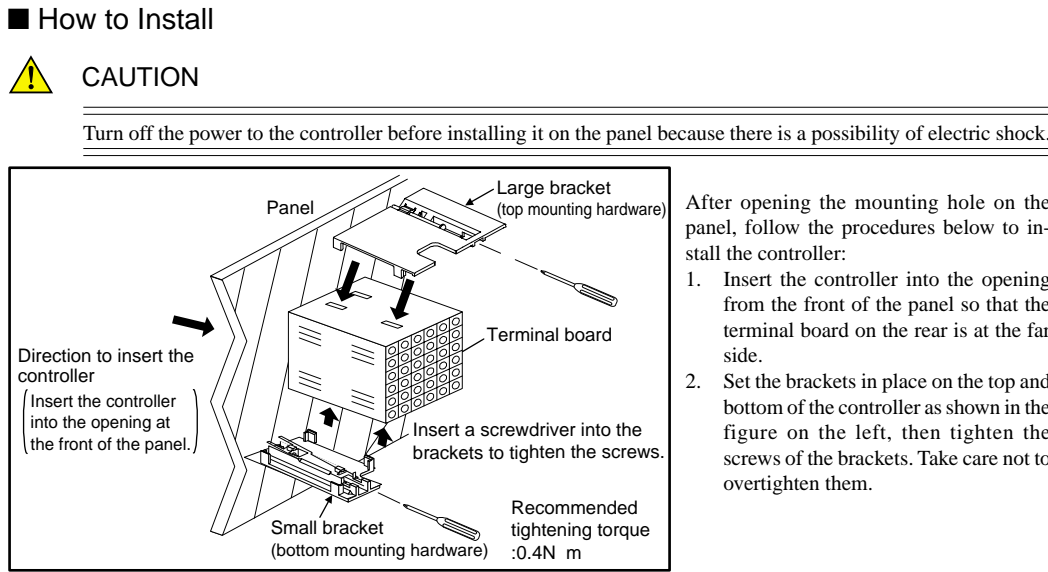
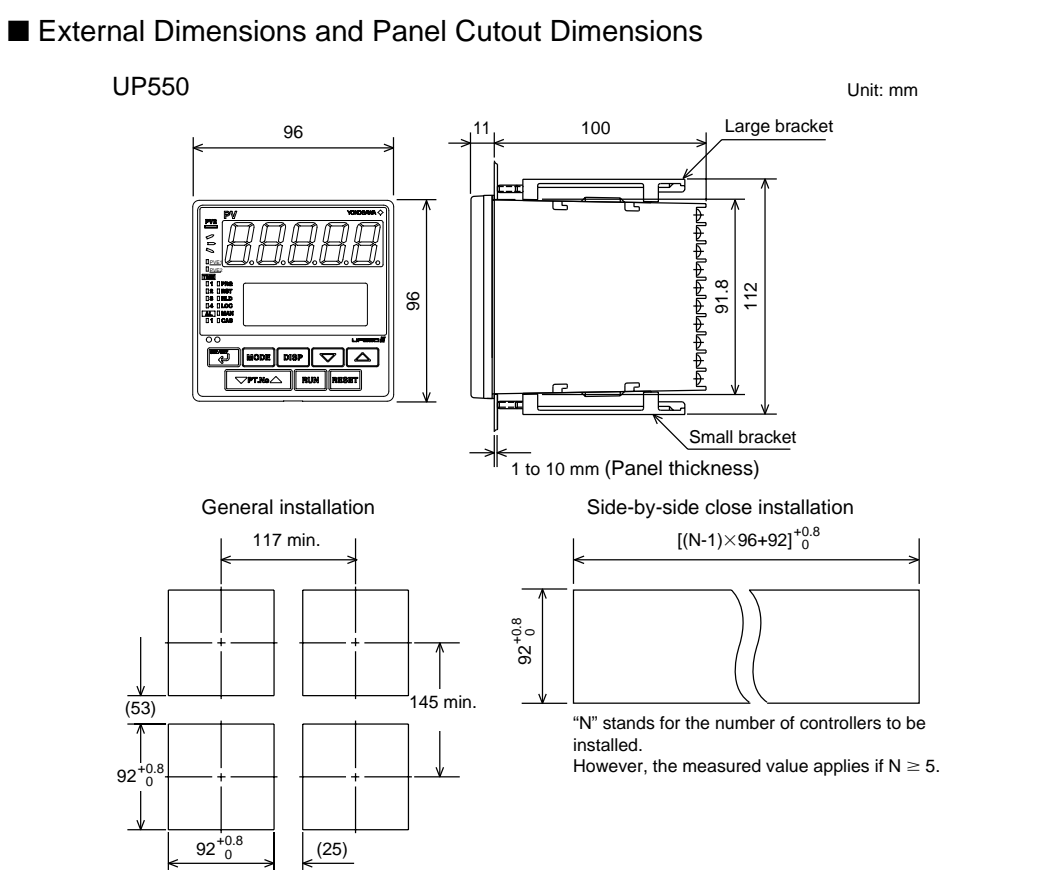
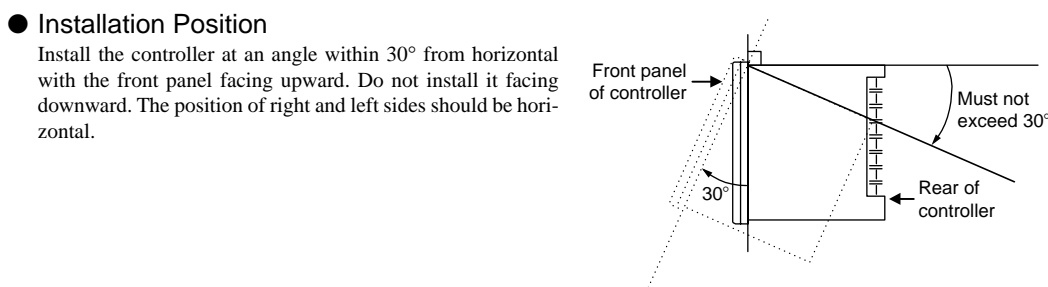

4. How to Connect Wires
CAUTION
 Available only for controllers with auxiliary analog input terminals. These signals are not used in single-loop control, however.
 • Number of inputs: 1 (terminals ①-③)
 • Input type: Settable in a range of 0-2, 0-10, 0.4-2.0, or 1-5 V DC
 • Sampling period: 100, 200 and 500 ms
 The sampling period of an auxiliary analog input signal is associated with the PV input's sampling period.
 • Input accuracy: About 1 mΩ
 • Input accuracy: ±0.3% ± 1 digit of input span for 0 to 2 V DC
 ±0.2% ± 1 digit of input span for 0 to 10 V DC
 ±0.375% ± 1 digit of input span for 0.4 to 2.0 V DC
 ±0.3% ± 1 digit of input span for 1 to 5 V DC
 Under standard operating conditions (23 ± 2°C, 55 ± 10% RH, power frequency of 50/60 Hz)

NOTE
 1) Provide power from a single-phase instrument power supply. If there is a lot of noise in the power line, insert an insulating transformer into the primary side of the line and use a line filter (recommended part: ZAC2205-00U from TDK) on the secondary side.
 As a countermeasure against noise, do not place the primary and secondary power cables close to each other.
 2) For thermocouple input, use shielded compensating lead wires for wiring. For RTD input, use shielded wires that have low conductor resistance and cause no significant differences in resistance between the three wires. The cables to be used for wiring, terminal specifications, and recommended parts are as shown below.
 3) Control output relays may be replaced. However, because they have a life of 100,000 times that of the resistance load, use auxiliary relays to turn on/off a load.
 4) The use of inductance (L) loads such as auxiliary relays, motors and solenoid valves causes malfunction or failure; always insert a CR filter for use with alternating current or a diode for use with direct current, as a spark-removal surge suppression circuit, into the line in parallel with the load.
 5) When there is possibility of being struck by external lightning surge, use the arrester to protect the instrument.

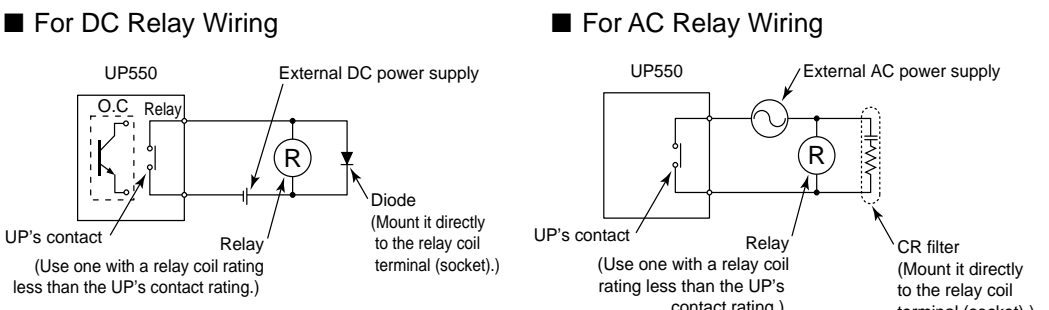

Cable Specifications and Recommended Cables

Purpose	Name and Manufacturer
Power supply, grounding, relay contact outputs	600 V PVC insulated wires, JIS C 3307, 0.9 to 2.0 mm ²
Thermocouple	Shielded compensating lead wires, JIS C 1610, □X-□-□-□ (See Yokogawa Electric's GS 6B1U1-E.)
RTD	Shielded wires (three conductors), UL2482 (Hitachi Cable)
Other signals	Shielded wires

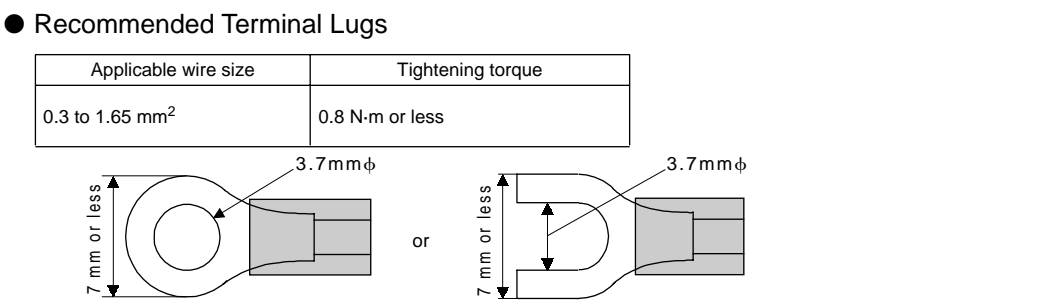

Terminal Covers (Optional parts)

Target Model	Part Number	Sales Unit
For UP550	T9115YD	1

- Before attaching the terminal cover, bend the side with the groove inward as shown in Fig. A. Be careful not to bend it backwards. This not only makes it harder to attach the cover but will also weaken its hold.
- Fit the holes on the top and bottom of the terminal cover the projections on the brackets (Fig. B) and lock in place. The figure right shows the attachment of a terminal cover to UP controller.

5. Hardware Specifications
PV Input Signals
 • Number of inputs: 1 (terminals ①-③)
 • Input type: Universal input system. The input type can be selected with the software.
 • Sampling period: Can be selected from 100, 200 and 500 ms.
 • Burnout detection: Functions at TC, RTD, standard signal (0.4 to 2 V or 1 to 5 V)
 Upscale, downscale, and off can be specified.
 For standard signal, burnout is determined to have occurred if it is 0.1 V or less.
 • Input bias current: 0.05 μA (for TC or RTD b-terminal)
 • Measurement current (RTD): About 0.13 mA
 • Input resistance: 1 MΩ or more for thermocouple or mV input
 About 1 MΩ for DC voltage input
 Effects of signal source resistance: 0.1 μV/Ω or less 2 kΩ or less for DC voltage input
 Effects of signal source resistance: About 0.01%/100 Ω
 • Allowable wiring resistance: for RTD input
 Maximum 150 Ω/wire: Conductor resistance between three wires should be equal
 However, 10 Ω/wire for a maximum range of -150.0 to 150.0°C.
 Wire resistance effect: ±0.1°C/10 Ω
 • Allowable input voltage: ±10 V DC for thermocouple, mV, or RTD input
 ±20 V DC for DC voltage input
 • Noise rejection ratio: 40 dB (50/60 Hz) or more in normal mode 120 dB (50/60 Hz) or more in common mode
 • Reference junction compensation error: ±1.0°C (15 to 35°C) ±1.5°C (0 to 15°C, 35 to 50°C)
 • Applicable standards: JIS, IEC, DIN (ITS-90) for thermocouples and RTD

Loop Power Supply
 Power is supplied to a two-wire transmitter. (15 V DC; terminals ④-⑥)
 A resistor (10 to 250 Ω) connected between the controller and transmitter converts a current signal into a voltage signal, which is then read via the PV input terminal. Supply voltage: 14.5 to 18.0 V DC, max. 21 mA (provided with a protection circuit against a field short-circuit)

Retransmission Output
 Either PV, program setpoint, or control output is output. Either the retransmission output or the loop power supply can be used with terminals ④-⑥.
 • Number of outputs: 1 or 2 (terminals ④-⑤, terminals ⑥-⑦)
 • Output signal: 4-20, 0-20, 20-4, or 20-0 mA DC (where, outputting signal levels of less than 0 mA is not feasible)
 • Load resistance: 600 Ω or less
 • Output accuracy: ±0.1% of span (±5% of span for 1 mA or less.) under standard operating conditions (23 ± 2°C, 55 ± 10% RH, power frequency of 50/60 Hz)

Control Output
 Universal output system. The output type can be selected with the software.
 Relay contact output(s) for the position proportional type
 • Current output
 (Standard type: terminals ④-⑤; heating-side output: terminals ⑥-⑦, cooling-side output: terminals ⑧-⑨)

Number of outputs	1 or 2 (two for heating/cooling type), switched between a voltage pulse output and current output.
Output signal	4-20, 0-20, 20-4, or 20-0 mA DC
Load resistance	600 Ω or less
Output accuracy	±0.1% of span (±5% of span for 1 mA or less) Under standard operating conditions (23 ± 2°C, 55 ± 10% RH, power frequency of 50/60 Hz)

 • Voltage pulse output
 (Standard type: terminals ④-⑤; heating-side output: terminals ⑥-⑦, cooling-side output: terminals ⑧-⑨)

Number of outputs	1 or 2 (two for heating/cooling type), switched between a voltage pulse output and current output.
Output signal	On-voltage = 12 V or more (load resistance: 600 Ω or more) Off-voltage = 0.1 V DC or less
Resolution	10 ms or 0.1% of output, whichever is larger

 • Relay contact output
 (Standard type: terminals ①-②-③, heating-side output: terminals ④-⑤, cooling-side output: terminals ⑥-⑧, ⑨, position proportional type: terminals ⑩-⑪-⑫)

Auxiliary Analog Input Signals
 Available only for controllers with auxiliary analog input terminals. These signals are not used in single-loop control, however.
 • Number of inputs: 1 (terminals ④-⑥)
 • Input type: Settable in a range of 0-2, 0-10, 0.4-2.0, or 1-5 V DC
 • Sampling period: 100, 200 and 500 ms
 The sampling period of an auxiliary analog input signal is associated with the PV input's sampling period.
 • Input accuracy: About 1 mΩ
 • Input accuracy: ±0.3% ± 1 digit of input span for 0 to 2 V DC
 ±0.2% ± 1 digit of input span for 0 to 10 V DC
 ±0.375% ± 1 digit of input span for 0.4 to 2.0 V DC
 ±0.3% ± 1 digit of input span for 1 to 5 V DC
 Under standard operating conditions (23 ± 2°C, 55 ± 10% RH, power frequency of 50/60 Hz)

Feedback Resistance Input
 Provided for position proportional type only (terminals ④-⑥, ⑧-⑨)
 • Slide resistance value: 100 Ω to 2.5 kΩ of overall resistance (burnout detection for sliding wire provided)
 • Measuring resolution: ±0.1% of overall resistance

Number of outputs	1 or 2 (two for heating/cooling type)
Output signal	Three terminals (NC, NO, and common)
Contact rating	250 V AC or 30 V DC, 3 A (resistance load)
Resolution	10 ms or 0.1% of output, whichever is larger

Contact Inputs
 • Purpose: Program pattern no. selection, and run/reset switching
 • Number of inputs: Differs with model and suffix codes as shown in the table below.

Model and Suffix Codes	Number of Inputs
UP550-□0	7
UP550-□1	8

 • Input type: Non-voltage contact or transistor open collector input
 • Input contact rating: 12 V DC, 10 mA or more
 • On/off determination: For non-voltage contact input, contact resistance of 1 kΩ or less is determined as "on" and contact resistance of 20 kΩ or more as "off."
 For transistor open collector input, input voltage of 2 V or less is determined as "on" and leakage current must not exceed 100 μA when "off."
 • Minimum status detection hold time: PV input's sampling period × 3

Contact Outputs
 • Purpose: Event output, FAIL output, and others
 • Number of outputs: 7 points
 • Relay contact rating: 240 V AC, 1 A, or 30 V DC, 1 A
 • Transistor contact rating: 24 V DC, 50 mA

Display Specifications
 • PV display:
 5-digit, 7-segment, red LEDs, character height of 8 mm
 • Setpoint display: 32 × 128 dot LCD with back lighting
 • Status indicating lamps: LEDs

Safety and EMC Standards
 • Safety: Compliant with IEC/EN61010-1: 2001, approved by CSA1010, approved by UL508.
 Installation category: CAT. II (IEC/EN61010, CSA1010)
 Pollution degree: 2 (IEC/EN61010, CSA1010)
 Measurement category: 1 (CAT. I: IEC/EN61010)
 Rated measurement input voltage: 10V DC max.(across terminals), 300V AC max.(across ground)
 Rated transient overvoltage: 1500V (Note)
 Note: It is a value on the safety standard which is assumed by IEC/EN61010-1 in measurement category I, and is not the value which guarantees an apparatus performance.

Environmental Conditions
 • Normal operating conditions:
 Ambient temperature: 0 to 50°C (40°C or less for side-by-side close installation)
 Temperature change rate: 10°C/h or less
 Ambient humidity: 20 to 90% RH (no condensation allowed)
 Magnetic field: 400 A/m or less
 Continuous vibration at 5 to 14 Hz: Full amplitude of 1.2 mm or less
 Continuous vibration at 14 to 150 Hz: 4.9 m/s² or less
 Short-period vibration: 14.7 m/s², 15 seconds or less
 Shock: 147 m/s² or less, 11 ms
 Installation height: Height above sea level of 2000 m or less
 Warm-up time: 30 minutes or more after power on
 • Transportation and storage conditions:
 Temperature: -25 to 70°C
 Humidity: 5 to 95% RH (no condensation allowed)
 • Effects of changes in operating conditions:
 - Effects from changes in ambient temperature:
 - On voltage or thermocouple input, ± 1 μV/°C or ±0.01% of F.S./°C, whichever is larger
 - On auxiliary analog input, ±0.02% of F.S./°C
 - On RTD input, ±0.05°C/°C (ambient temperature) or less
 - On analog output, ±0.05% of F.S./°C or less
 - Effects from power supply fluctuation (within rated voltage range)
 - On analog input, ± 1 μV/10 V or ±0.01% of F.S./10 V, whichever is larger
 - On analog output, ±0.05% of F.S./10 V or less

CAUTION
 This equipment has Measurement category I, therefore do not use the equipment for measurements within measurement categories II, III and IV.

Measurement category	Description	Remarks
I	CAT. I	For measurements performed on circuits not directly connected to Mains
II	CAT. II	For measurements performed on circuits directly connected to the low voltage installation.
III	CAT. III	For measurements performed in the building installation.
IV	CAT. IV	For measurements performed at the source of the low-voltage installation.

Construction, Installation, and Wiring
 • Construction: Only the front panel is dust-proof and drip-proof (protection class IP55)
 For side-by-side close installation the controller loses its dust-proof and drip-proof protection.
 • Material: ABS resin and polycarbonate
 • Case color: Black
 • Weight: About 1 kg or less
 • Dimensions:
 96 (W) × 96 (H) × 100 (depth from panel face) mm
 • Installation: Panel-mounting type. With top and bottom mounting hardware (1 each)
 • Panel cutout dimensions:
 92^{+0.8} (W) × 92^{+0.8} (H) mm
 • Installation position: Up to 30° upward facing (not designed for facing downward)
 • Wiring: M3.5 screw terminals (for signal wiring and power/ground wiring as well)

Power Supply Specifications
 • Power supply: Rated voltage of 100 to 240 V AC (±10%), 50/60 Hz
 • Power consumption: Max. 20 VA (8.0 W max.)
 • Internal fuse rating: 250 V AC, 1.6A time-lag fuse
 • Data backup: Lithium battery with life expectancy of 10 years
 • Withstanding voltage
 - Between primary terminals* and secondary terminals**:
 At least 1500 V AC for 1 minute
 - Between primary terminals* and grounding terminal:
 At least 1500 V AC for 1 minute
 - Between grounding terminal and secondary terminals**:
 At least 1500 V AC for 1 minute
 - Between secondary terminals**:
 At least 500 V AC for 1 minute
 * Primary terminals indicate power terminals and relay output terminals
 ** Secondary terminals indicate analog I/O signal, voltage pulse output, and contact input terminals
 • Insulation resistance: 20 MΩ or more at 500 V DC between power terminals and grounding terminal
 • Grounding: Class D grounding (grounding resistance of 100 Ω or less)

6. Terminal Wiring Diagrams

NOTE
Do not use unassigned terminals as relay terminals.

UP550 Standard Type (Model UP550-0□) or Heating/Cooling Type (Model UP550-2□), Single-loop Control

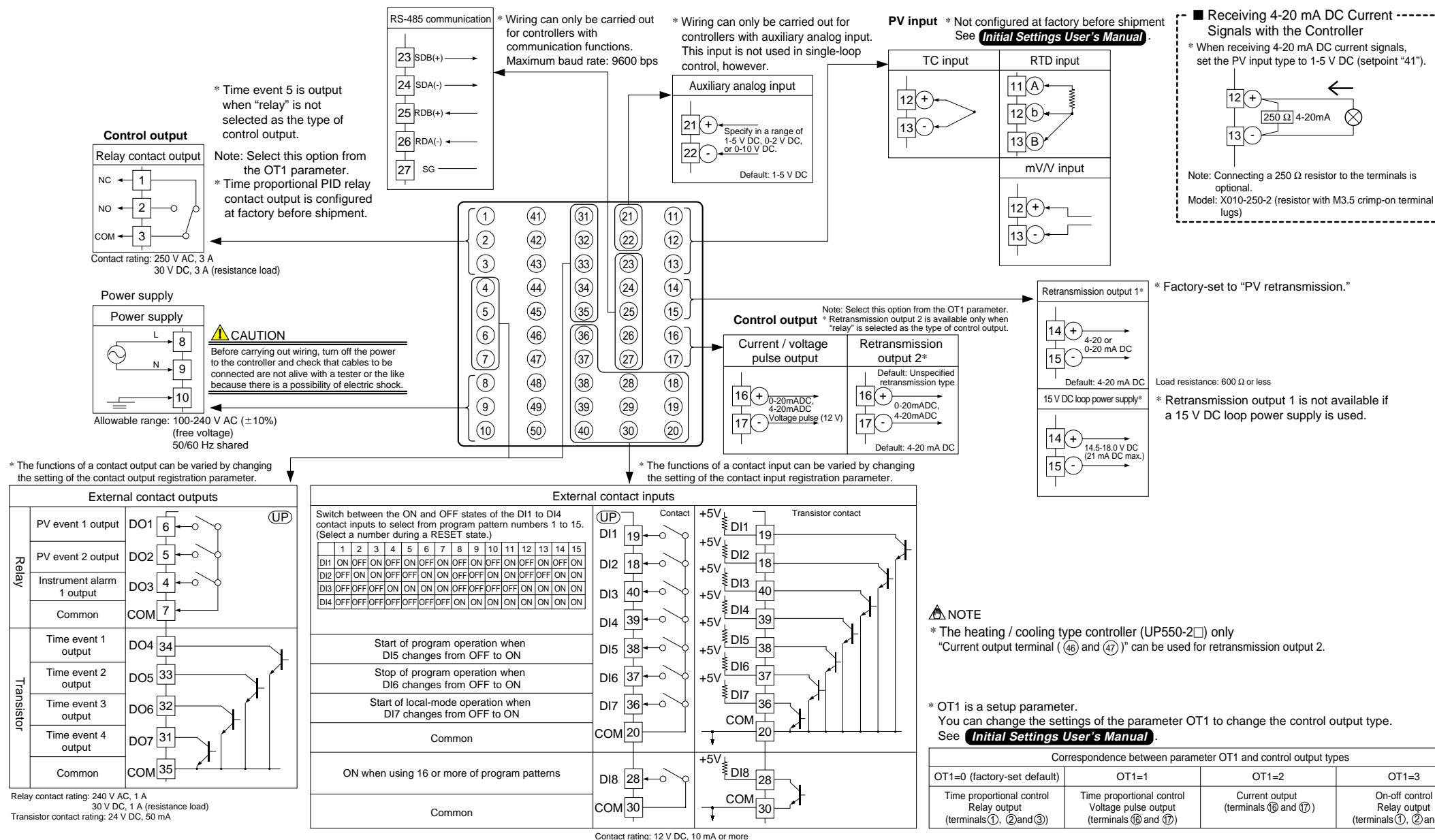

UP550 Heating/Cooling Type (Model UP550-2□), Single-loop Heating/Cooling Control

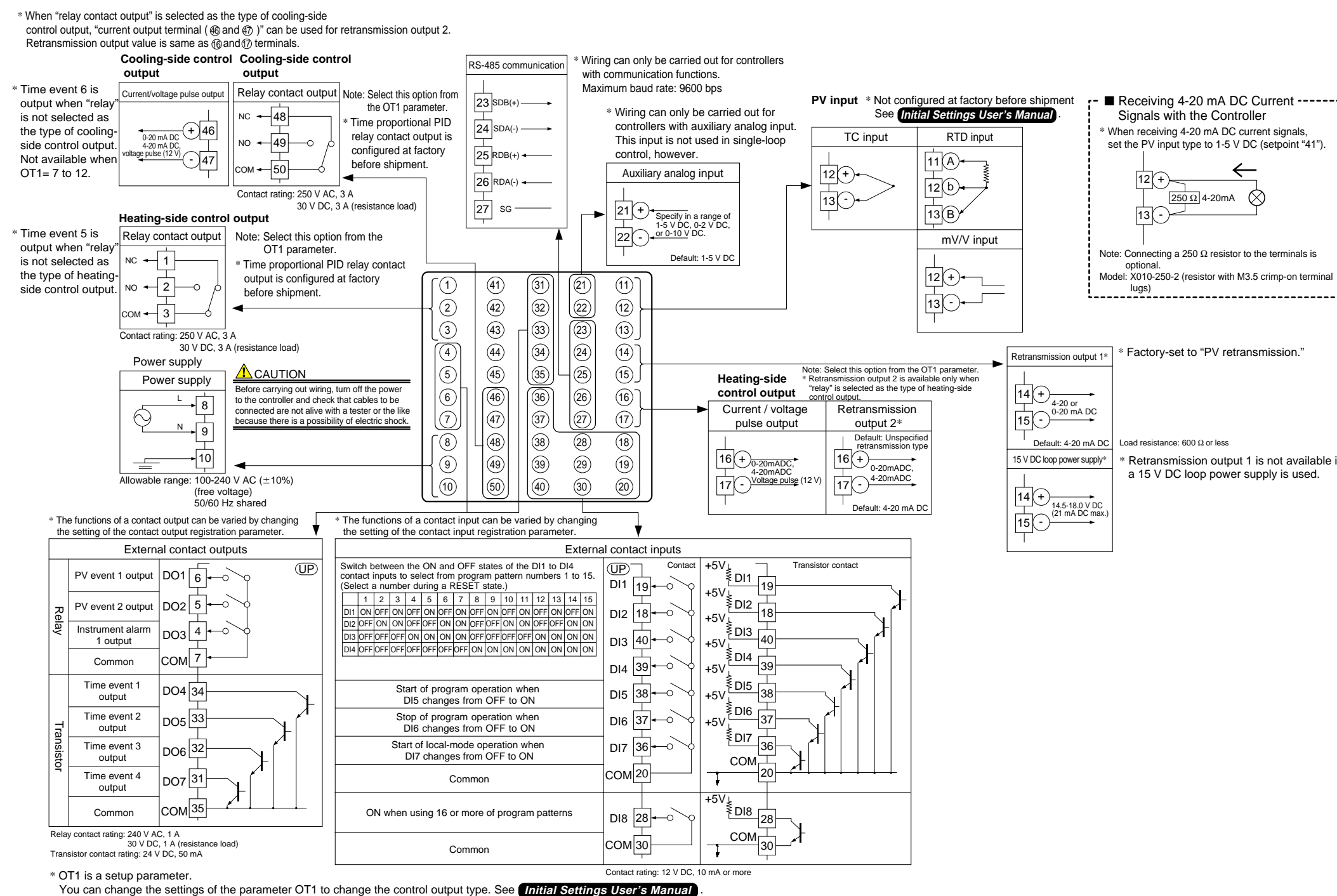

UP550 Position Proportional Type (Model UP550-1□) Single-loop Position Proportional Control

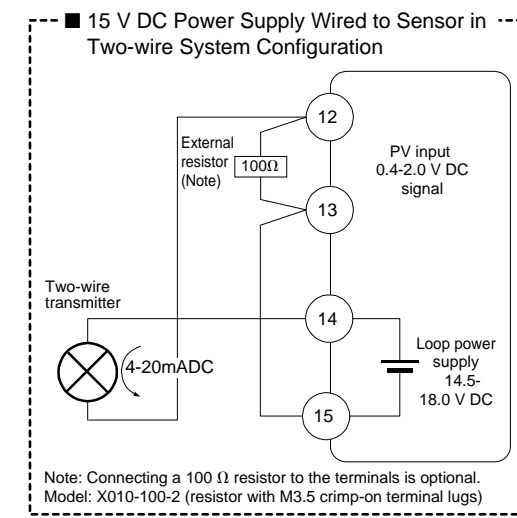
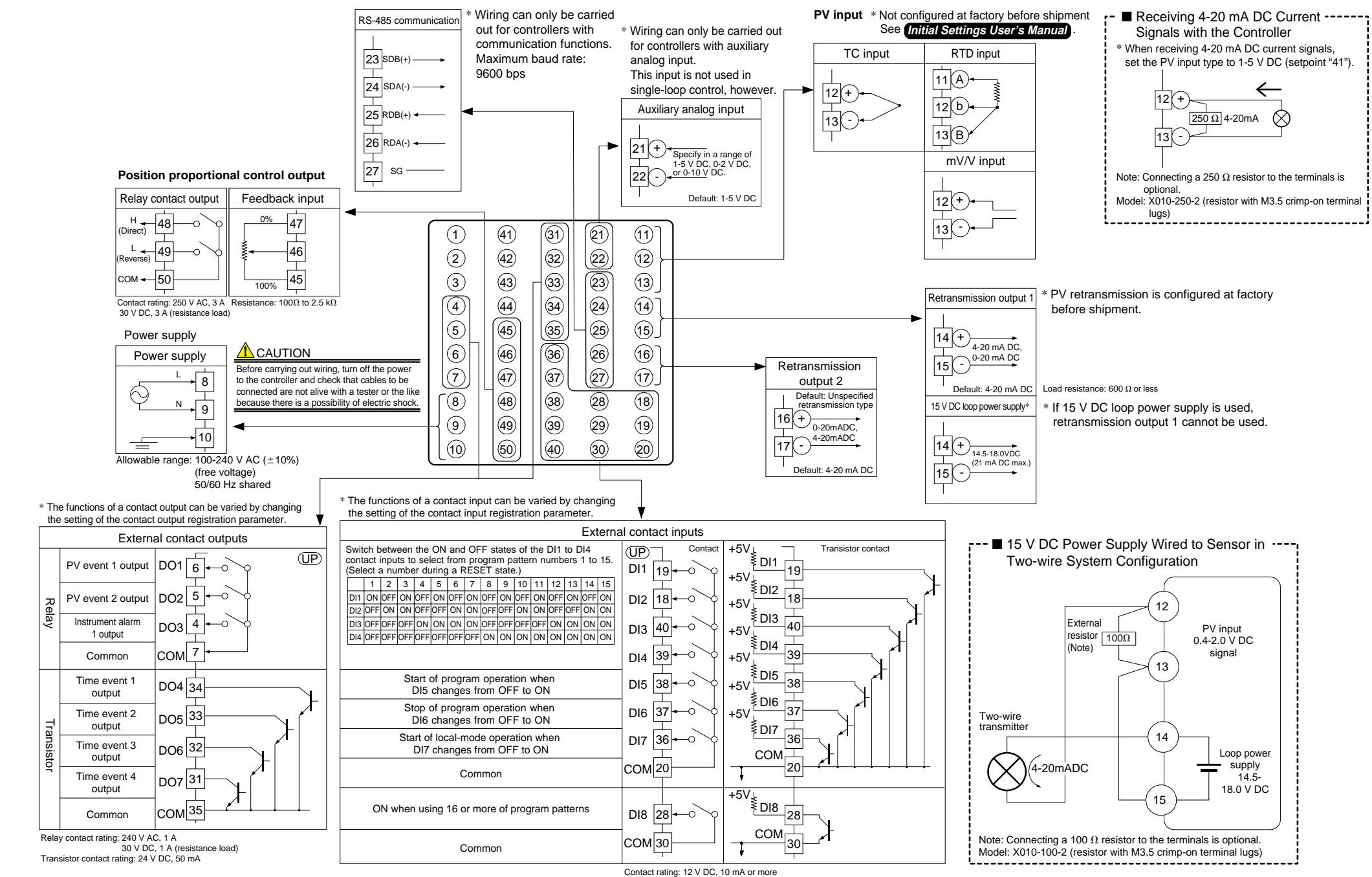



YOKOGAWA Yokogawa Electric Corporation

This manual describes examples of setting PV input types, control output types. Carrying out settings described herein allows you to perform basic control. Refer to examples of various settings to understand how to set parameters required. Refer to **Parameter Map User's Manual** for an easy to understand explanation of setting various parameters. If you cannot remember how to carry out an operation during setting, press the **DISP** key no more than four times. This brings you to the display (operating display) that appears at power-on. After carrying out the setting describes here, create programs in **Programming User's Manual**.

Contents

- Names and Functions of Front Panel Parts
- Setting PV Input Type (Setting First at Power-on)
- Changing PV Input Type
- Setting Control Output Type (except for a Position Proportional Controller)
- Calibrating Valve Position (for a Position Proportional Controller Only)
- Initializing Parameters

1. Names and Functions of Front Panel Parts

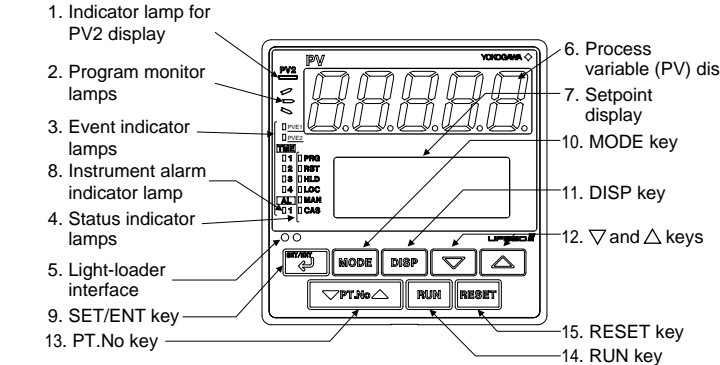

Name of Part	Function
1. Indicator lamp for PV2 display	Is lit when secondary PV is displayed in PV display. Not used in single-loop control.
2. Program monitor lamps	<ul style="list-style-type: none"> Is lit (in green) when a program setpoint is increasing. Is lit (in green) when a program setpoint is constant. Is lit (in green) when a program setpoint is decreasing.
3. Event indicator lamps	Show the statuses of PV events, time events and instrument alarms in orange. PVE1 and PVE2 lamps: Come on when PV event 1 and PV event 2 turn on. TME1 to TME4 lamps: Come on when time event 1 to time event 4 turn on. AL1 lamp: Comes on when instrument alarm 1 turns on.
4. Status indicator lamps	Is lit (in green) to indicate the status of operation or control. PRG: Is lit when in program mode. RST: Is lit when in reset mode. HLD: Is lit when in hold mode. LOC: Is lit when in local mode. MAN: Is lit when in manual mode. CAS: Not used in single-loop control.
5. Light-loader interface	Interface for an adapter cable used when setting and storing parameters from a PC. This requires an optional parameter setting tool.
6. Process variable (PV) display	Displays PV. Displays an error code (in red) if an error occurs.
7. Setpoint display (LCD)	Displays the name and value of a program setpoint (SP), output (OUT), deviation trend, valve opening, or a parameter. Displays an error code if an error occurs.
8. Instrument alarm indicator lamp	The AL1 lamp comes on in orange if instrument alarm 1 occurs.
9. SET/ENT key	Used to switch or register a parameter. Pressing the key for more than 3 seconds allows you to switch between the operating display and the main menu for operating parameter setting display alternately.
10. MODE key	Presents a display for switching between the hold, advance, local, AUTO and MAN modes.
11. DISP key	Used to switch between displays. Pressing this key while any operating display is shown lets you switch to another prearranged operating display. Pressing this key while any display other than an operating display is shown lets you go one display back. (One to four presses (maximum) of this key lets you return to the current operating display, though the number of presses depends on the operating status.)
12. ∇ and ∆ keys	Used to change numerical values. On setting displays for various parameters, you can change target setpoints, parameters, and output values (in manual operation). Pressing the ∇ key decreases a numerical value, while pressing the ∆ key causes it to increase. You can hold down a key to gradually increase the speed of change. These keys also switch between menu displays when main menu on submenu of parameter setting display is shown.
13. PT.No key	Use this key when the controller is at a reset to select a program pattern number on an operating display.
14. RUN key	Pressing this key for more than 2 seconds while an operating display is shown starts the controller.
15. RESET key	Pressing this key for more than 2 seconds while an operating display is shown stops the controller.

Setting of Main Parameters at the Factory before Shipment

Item	Factory-set defaults for standard type controllers	Factory-set defaults for heating/cooling type controllers	Factory-set defaults for position proportional type controllers
Control output	Time proportional PID relay output (variable)	Heating side: Time proportional PID relay output (variable) Cooling side: Time proportional PID relay output (variable)	Relay output (fixed)
Control action	Reverse action (variable)	Not specified	
PID parameter	P = 5.0%, I = 240 seconds, D = 60 seconds.		

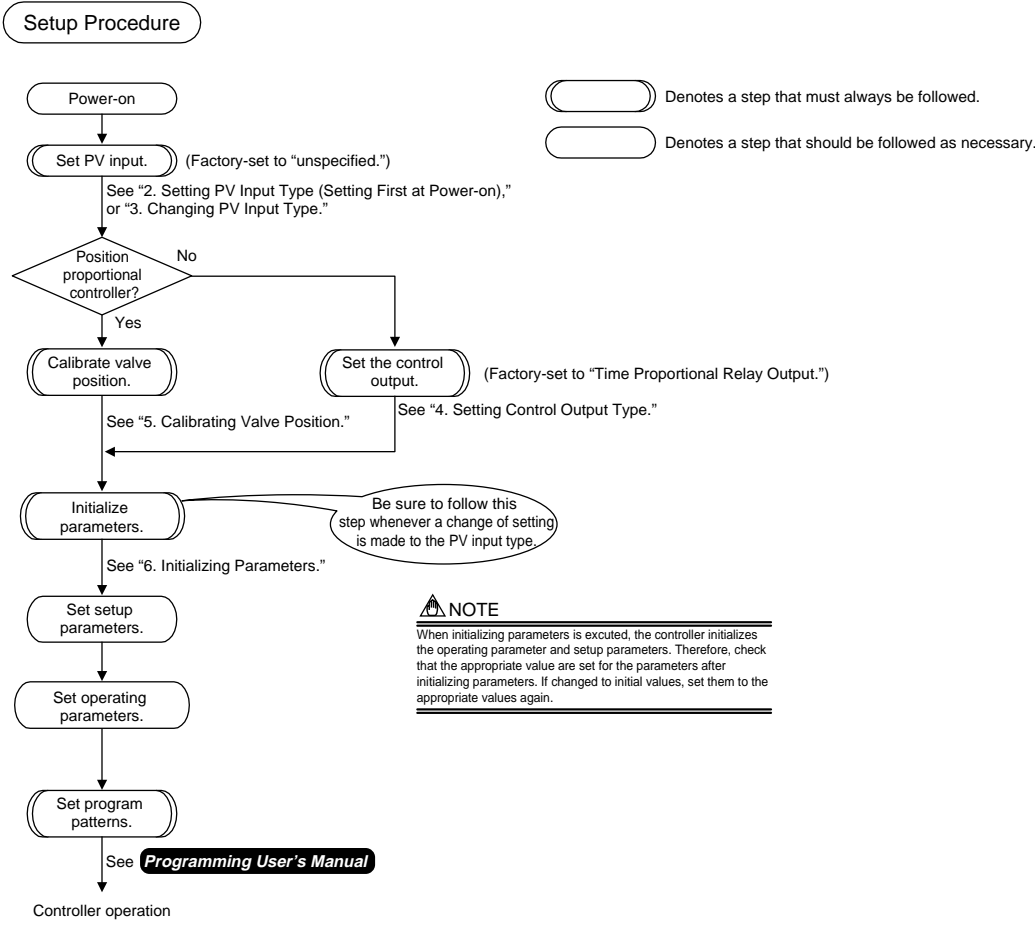

2. Setting PV Input Type (Setting First at Power-on)

NOTE

- The controller displays an operating display when the power is turned on. The submenu "IN" appears at this point if the type of PV input has not been defined yet. In this case, first press the **IN** key once to display the parameter "IN1" for the PV input type, and use the **∆** key to display the input range code to use, then press the **∆** key to register it. Then, set the maximum value (RH1) and minimum value (RL1) of the PV input range (for voltage input, set the maximum value (SH1) and minimum value (SL1) of the PV input scale). See the operating procedure below for more details.
- The controller is configured to the default of each parameter at the factory before shipment. First check these defaults listed in **Parameters User's Manual**, and change their values if necessary.

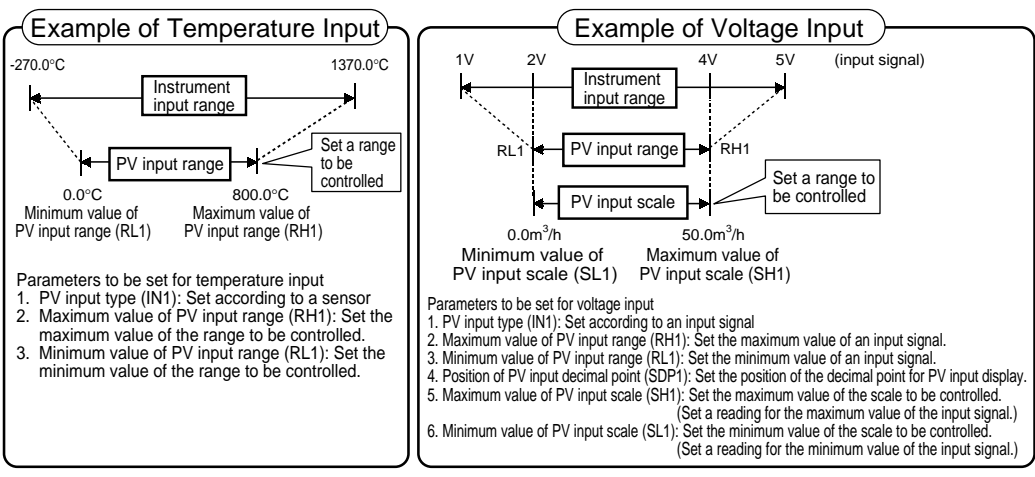

How to return to a menu
 Press the **DISP** key once during parameter setting. This lets you return to the parameter menu.

The following operating procedure describes an example of setting a K-type thermocouple (-200.0 to 500.0°C) and a measurement range of 0.0 to 200.0°C.

- Display view at power-on. The PV display in the figure on the left shows the error code for input burnout (bOUT) if PV input wiring is not yet complete. The error code disappears when you wire the PV input terminals correctly.
- Press the **IN** key once to display the parameter IN1 (PV input type). In steps 2 and later, illustrations of the LCD are cited to explain the procedure.
- Press the **∆** or **∇** key to display the required setpoint. The figure below shows an example of setting the maximum value of the PV input range to 200.0°C.
- Press the **∆** or **∇** key to display the required setpoint. The figure below shows an example of setting a K-type thermocouple (-200.0°C to 500.0°C). See "Instrument Input Range Codes."
- Press the **∆** key once to register the setpoint.
- Press the **∆** or **∇** key to display the required setpoint. The figure below shows an example of setting the minimum value of the PV input range to 0.0°C.
- Press the **∆** key once to display the parameter "RH1" (maximum value of PV input range).
- Press the **∆** or **∇** key to display the required setpoint. The figure below shows an example of setting the minimum value of the PV input range to 0.0°C.
- Press the **∆** key once to display the parameter "UN1" (PV input unit).
- Press the **∆** or **∇** key to display the required setpoint. The figure below shows an example of setting the minimum value of the PV input range to 0.0°C.
- Press the **∆** key once to register the setpoint.
- Press the **∆** key once to register the setpoint.

Instrument Input Range Codes

Input	Type	Instrument Input Range Code	Instrument Input Range	Input Type "IN1" to the OFF option to leave the PV input type undefined.	Measurement Accuracy
Thermocouple	K	type K1	-270.0 to 1370.0°C -450.0 to 2500.0°F	Set the data item PV Input Type "IN1" to the OFF option to leave the PV input type undefined.	±0.1% of instrument range ±1 digit at 0°C or more ±0.2% ±1 digit for temperatures below 0°C, where the accuracy is: ±2% of instrument range ±1 digit for temperatures below -200.0°C for a type-K thermocouple, or ±1% of instrument range ±1 digit for temperatures below -200.0°C for a type-T thermocouple.
		type K2	-270.0 to 1000.0°C -450.0 to 2300.0°F		
		type K3	-200.0 to 500.0°C -300.0 to 1000.0°F		
	J	type J	-200.0 to 1200.0°C -300.0 to 2300.0°F		
		type T	-270.0 to 400.0°C -450.0 to 750.0°F		
	B	type T1	0.0 to 400.0°C -200.0 to 750.0°F		
		type T2	0.0 to 1800.0°C 32 to 3300°F		
	S	type B	0.0 to 1800.0°C 32 to 3300°F		
		type S	0.0 to 1700.0°C 32 to 3100°F		
	R	type R	0.0 to 1700.0°C 32 to 3100°F		
type N		-200.0 to 1300.0°C -300.0 to 2400.0°F	±0.1% of instrument range ±1 digit ±0.25% of instrument range ±1 digit for temperatures below 0°C		
L(DIN)	type E	-270.0 to 1000.0°C -450.0 to 1800.0°F	±0.1% of instrument range ±1 digit at 0°C or more ±0.2% ±1 digit for temperatures below 0°C, where the accuracy is: ±1.5% of instrument range ±1 digit for temperatures below -200.0°C for a type-E thermocouple.		
	type L	-200.0 to 900.0°C -300.0 to 1600.0°F			
U(DIN)	type U1	-200.0 to 400.0°C -300.0 to 750.0°F	±0.1% of instrument range ±1 digit at 0°C or more ±0.2% ±1 digit for temperatures below 0°C, where the accuracy is: ±1.5% of instrument range ±1 digit for temperatures below -200.0°C for a type-E thermocouple.		
	type U2	0.0 to 400.0°C -200.0 to 1000.0°F			
W	type W	0.0 to 2300.0°C 32 to 4200°F	±0.2% of instrument range ±1 digit		
Platinel 2	Plati 2	0.0 to 1390.0°C 32 to 2500.0°F	±0.1% of instrument range ±1 digit		
PR20-40	PR2040	0.0 to 1900.0°C 32 to 3400°F	±0.5% of instrument range ±1 digit at 800°C or more No accuracy is guaranteed at less than 800°C		
W97Re3-W75Re25	W97Re3	0.0 to 2000.0°C 32 to 3600°F	±0.2% of instrument range ±1 digit		
RTD	JPt100	JPt1	-200.0 to 500.0°C -300.0 to 1000.0°F	±0.1% of instrument range ±1 digit (Note1) (Note2)	
		JPt2	-150.0 to 150.00°C -20.0 to 300.0°F		
	Pt100	Pt1	-200.0 to 850.0°C -300.0 to 1560.0°F		
		Pt2	-200.0 to 500.0°C -300.0 to 1000.0°F		
Standard signal	DC voltage	0.4 to 2 V	0.4 to 2 V 0.400 to 2.000 V	±0.1% of instrument range ±1 digit Display range is scalable in a range of -19999 to 30000. Display span is 30000 or less.	
		1 to 5 V	1 to 5 V 1.000 to 5.000 V		
DC voltage	mV1	0 to 10 V	0 to 10 V 0.000 to 2.000 V	±0.1% of instrument range ±1 digit Display range is scalable in a range of -19999 to 30000. Display span is 30000 or less.	
		-10 to 20 mV	-10.00 to 20.00 mV 0.0 to 100.0 mV		

* Performance in the standard operating conditions (at 23±2°C, 55±10%RH, and 50/60 Hz power frequency)
 Note1: The accuracy is ±0.3°C of instrument range ±1 digit for a temperature range from 0°C to 100°C.
 Note2: The accuracy is ±0.5°C of instrument range ±1 digit for a temperature range from -100°C to 200°C.
 * To receive a 4-20 mA DC signal, select a standard signal of 1 to 5 V DC and connect it to a 250Ω resistor. This resistor is optional.
 Model: X010-250-2 (resistor with M3.5 crimp-on terminal lugs)

NOTE
 The controller may automatically initialize the registered operating parameter setpoints if any change is made to the data item PV Input Type (IN1), Maximum Value of PV Input Range (RH1), Minimum Value of PV Input Range (RL1), PV Input Decimal Point Position (SDP1), Maximum Value of PV Input Scale (SH1) or Minimum Value of PV Input Scale (SL1). After a change has been made to any of these data items, be sure to verify the registered operating parameter setpoints to ensure that they are correct. If any data item has been changed to its default, set it to a required value.

Ranges Selectable for PV Input

Thermocouple	typeK1, K2, K3, J, T1, T2, B, S, R, N, E, L, U1, U2, W, Plati2, PR2040
RTD	JPt1, JPt2, Pt1, Pt2, Pt3, Pt4
DC voltage(mV,V)	0.4 to 2 V, 1 to 5 V, 0 to 2 V, 0 to 10 V, mV1, mV2

3. Changing PV Input Type

The following operating procedure describes an example of changing the setting of K-type thermocouple (-200.0 to 500.0°C) to RTD Pt100 (-200.0 to 500.0°C) and a measurement range of 0.0 to 200.0°C.

PV input terminal
Thermocouple/m/V input..... ②-③
RTD input..... ①-②-③

- Bring the operating display into view (display appears at power-on).
- Press the **[F1]** key for more than 3 seconds to call up the main menu "PROG".
- Press the **[F2]** key once to display the main menu "STUP".
- Press the **[F3]** key once to display the main menu "PARA".
- Press the **[F4]** key once to display the main menu "UPMD".
- Press the **[F5]** key once to display the submenu "MD".
- Press the **[F6]** key once to display the submenu "IN".
- Press the **[F7]** key once to display the parameter "IN1" (PV input type).
- Press the **[F8]** or **[F9]** key to display the required setpoint. The figure below shows an example of setting the PV input type to a Pt100 resistance temperature detector (-200.0°C to 500.0°C).
- Press the **[F10]** key for more than 3 seconds. This returns you to the display shown at power-on (figure below).

In steps 2 and later, illustrations of the LCD are cited to explain the procedure.

10. Press the **[F1]** key once to register the setpoint.

11. Press the **[F2]** key once to display the parameter "UNI".

12. Press the **[F3]** key once to display the parameter "RH1" (maximum value of PV input range).

13. Press the **[F4]** or **[F5]** key to display the required setpoint. The figure below shows an example of setting the maximum value of the PV input range to 200.0°C.

14. Press the **[F6]** key once to register the setpoint.

15. Press the **[F7]** key once to display the parameter "RL1" (minimum value of PV input range).

16. Press the **[F8]** or **[F9]** key to display the required setpoint. The figure below shows an example of setting the minimum value of the PV input range to 0.0°C.

17. Press the **[F10]** key once to register the setpoint.

18. Press the **[F1]** key for more than 3 seconds. This returns you to the display shown at power-on (figure below).

If the type of Input is voltage, also configure the PV Input Decimal Point Position (SDP1), Maximum Value of PV Input Scale (SH1), and Minimum Value of PV Input Scale (SL1) parameters that follow this step.

4. Setting Control Output Type (except for a Position Proportional Controller)

The following operating procedure describes an example of changing time proportional PID relay output (0: factory-set default) to current output (2).

Control output terminal Values in parentheses are setpoints
Time proportional PID relay (0/on-off(3) output..... ①-②-③
Current (2)/time proportional PID voltage pulse (1) output..... ④-⑤
For details on the output terminals for heating/cooling control, see "6. Terminal Wiring Diagrams" in **Installation User's Manual**.

- Bring the operating display into view (display appears at power-on).
- Press the **[F1]** key for more than 3 seconds to call up the main menu "PROG".
- Press the **[F2]** key once to display the main menu "STUP".
- Press the **[F3]** key once to display the main menu "PARA".
- Press the **[F4]** key once to display the main menu "UPMD".
- Press the **[F5]** key once to display the submenu "MD".
- Press the **[F6]** key for more than 3 seconds. This returns you to the display shown at power-on (figure below).

In steps 2 and later, illustrations of the LCD are cited to explain the procedure.

7. Press the **[F7]** key twice to display the submenu "OUT".

8. Press the **[F8]** key once to display the parameter "OT1" (control output type).

9. Press the **[F9]** or **[F10]** key to display the required setpoint. The figure below shows an example of setting to current output (4 to 20 mA DC).

10. Press the **[F1]** key once to register the setpoint.

11. Press the **[F1]** key for more than 3 seconds. This returns you to the display shown at power-on (figure below).

List of Control Output Types

Parameter Symbol	Name of Parameter	Setpoint	Control Output Types	
OT1	Control output type	0	Time proportional PID relay contact output (terminals ①-②-③)	
		1	Time proportional PID voltage pulse output (terminals ④-⑤)	
		2	Current output (terminals ⑥-⑦)	
		3	On/off control relay contact output (terminals ①-②-③)	
		The following 4 to 12 are displayed only for heating/ cooling type controllers.		
		4	Heating-side relay output (terminals ①-②-③), cooling-side relay output (terminals ④-⑤-⑥)	
		5	Heating-side pulse output (terminals ⑥-⑦), cooling-side relay output (terminals ⑧-⑨-⑩)	
		6	Heating-side current output (terminals ⑥-⑦), cooling-side relay output (terminals ⑧-⑨-⑩)	
		7	Heating-side relay output (terminals ①-②-③), cooling-side pulse output (terminals ④-⑤-⑥)	
		8	Heating-side pulse output (terminals ⑥-⑦), cooling-side pulse output (terminals ⑧-⑨-⑩)	
		9	Heating-side current output (terminals ⑥-⑦), cooling-side pulse output (terminals ⑧-⑨-⑩)	
		10	Heating-side relay output (terminals ①-②-③), cooling-side current output (terminals ④-⑤-⑥)	
11	Heating-side pulse output (terminals ⑥-⑦), cooling-side current output (terminals ⑧-⑨-⑩)			
12	Heating-side current output (terminals ⑥-⑦), cooling-side current output (terminals ⑧-⑨-⑩)			

5. Calibrating Valve Position (for a Position Proportional Controller Only)

The following operation describes a procedure of inputting a feedback signal from a control valve to calibrate the full closed and full open positions of the valve automatically. To calibrate the valve position, you need to carry out wire connections and bring the controller into manual mode. For connections, see "6. Terminal Wiring Diagrams" in **Installation User's Manual** and for entering the manual mode, see "6. Switching between AUTO and MAN" in **Operations User's Manual**.

If the controller is in RESET mode, you need to bring the controller into program operation (RUN) or local operation (LOCAL). For entering the program operation, see "5. Switching between RUN and RESET Modes" in **Operations User's Manual**, and entering the local operation, see "11. Switching to Local-mode (LOCAL) Operation" in **Operations User's Manual**.

- Bring the operating display into view (display appears at power-on).
- Press the **[F1]** key for more than 3 seconds to call up the main menu "PROG".
- Press the **[F2]** key once to display the main menu "STUP".
- Press the **[F3]** key once to display the main menu "PARA".
- Press the **[F4]** key once to display the main menu "UPMD".
- Press the **[F5]** key once to display the submenu "MD".
- Press the **[F6]** key three times to display the submenu "VALV".
- Press the **[F7]** key for more than 3 seconds. This returns you to the display shown at power-on (figure below).

In steps 2 and later, illustrations of the LCD are cited to explain the procedure.

8. Press the **[F8]** key once to display the parameter "V.AT".

9. Press the **[F9]** key to display "ON".

10. Press the **[F1]** key once. The controller automatically calibrates the valve position (fully open or closed).

11. Calibration has ended successfully when the indication changes from "ON" to "OFF".

12. Calibration has ended unsuccessfully if the indication changes from "ON" to "ERR". Check the feedback input wiring and carry out automatic calibration again.

13. Press the **[F1]** key for more than 3 seconds. This returns you to the display shown at power-on (figure below).

6. Initializing Parameters

Be sure to follow the steps below after a change of setting has been made to the data item PV Input Type, PV Input Range or PV Input Scale.

CAUTION

Initializing the above parameter setpoints may initialize the registered operating/setup parameter setpoints. Check that they are correct. If any of them has been changed to its initial value, set it to a required value.

- Bring the operating display into view (display appears at power-on).
- Press the **[F1]** key for more than 3 seconds to call up the main menu "PROG".
- Press the **[F2]** key once to display the main menu "STUP".
- Press the **[F3]** key once to display the main menu "PARA".
- Press the **[F4]** key once to display the main menu "UPMD".
- Press the **[F5]** key once to display the submenu "MD".
- Press the **[F6]** key for more than 3 seconds. This returns you to the display shown at power-on (figure below).

In steps 2 and later, illustrations of the LCD are cited to explain the procedure.

7. Press the **[F7]** key twice to display the submenu "INIT".

8. Press the **[F8]** key once to display the parameter "INI".

9. Press the **[F9]** key to display "ON".

10. Press the **[F1]** key once. The display momentarily becomes blank (which is normal), indicating the parameters have been initialized.

11. Press the **[F1]** key for more than 3 seconds. This returns you to the display shown at power-on (figure below).

This manual explains how to create programs by citing specific examples. Create user programs by referring to the given programming examples. Use the parameter map included in "2. Program Parameter Map," in **Program Parameters User's Manual**, in order to further familiarize yourself with the required operations. Be sure to carry out the settings instructed in **Initial Settings User's Manual** before beginning any of the tasks discussed in this manual.

Contents

1. Overview of Program Patterns
2. Example of Program Pattern Setup Charts
3. Creating Program Patterns
4. Changing Program Patterns

1. Overview of Program Patterns

■ Programming Overview

- The programming example given here demonstrates how to do the tasks outlined below.
1. Program the controller to start program operation at 25°C and raise the temperature up to 80°C in 20 minutes.
 2. When the temperature reaches 80°C, keep it at this level for 80 minutes.
 3. Finally, lower the temperature to 0°C in 10 minutes.

- Event output
- Set a deviation of 5°C on both the positive and negative sides of a program setpoint to allow the controller to output an event signal if the temperature goes beyond the deviation range.
 - Let the controller output an event signal when the temperature stabilizes to 80°C.

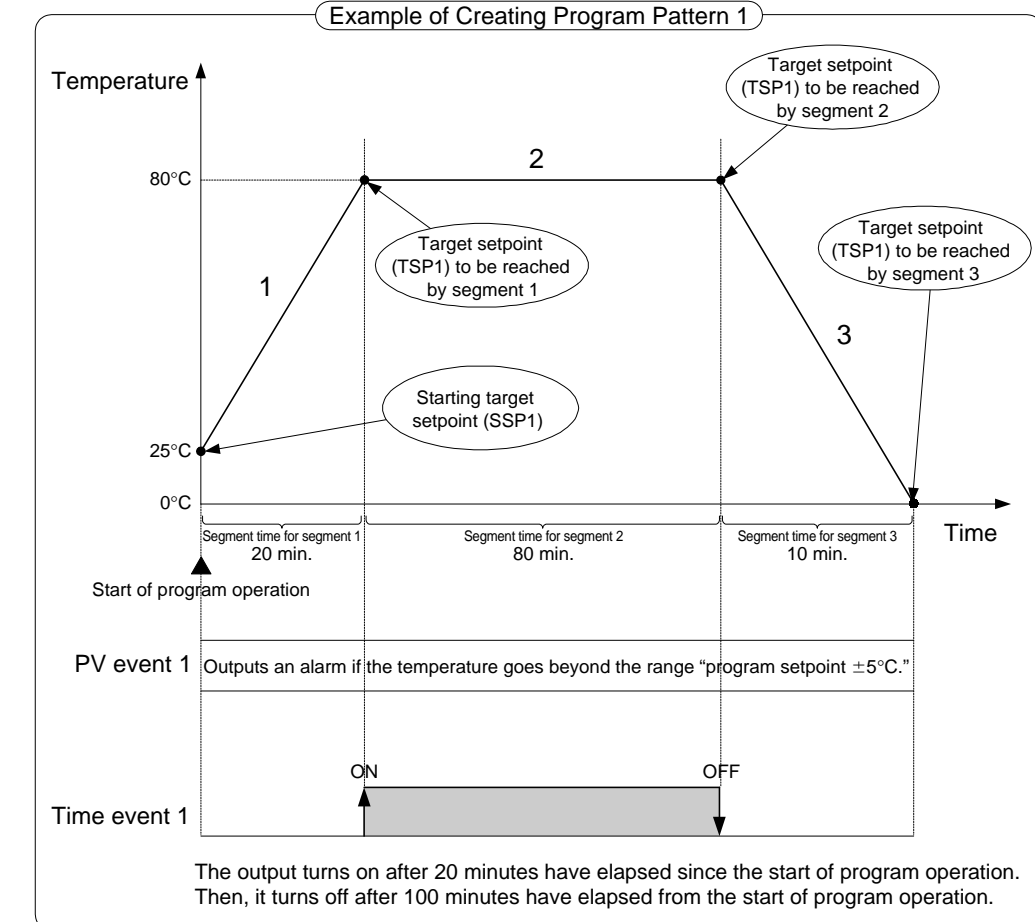

2. Example of Program Pattern Setup Charts

Complete the following setup chart before setting programs in the controller. Filling in the chart makes it easier for you to input program data into the controller. See "1. Program Pattern Setup Charts," in **Program Parameters User's Manual**. In the following chart, fill in the fields with bold-face borders.

1. Maximum value of PV input range: Setpoint of the "Maximum Value of PV Input Range (RH1)" setup parameter
2. Minimum value of PV input range: Setpoint of the "Minimum Value of PV Input Range (RL1)" setup parameter
3. PV input unit: Setpoint of the "PV Input Unit (UNI)" setup parameter
4. Program time unit: Setpoint of the "Program Time Unit (TMU)" setup parameter
5. Segment setting method: Setpoint of the "Segment Setting Method (SEG.T)" setup parameter
6. Starting target setpoint: Setpoint of the "Starting Target Setpoint (SSP1)" program parameter
7. Start code: Setpoint of the "Start Code (STC)" program parameter
8. Final target setpoint, Segment time, Events (PV event and Time event), and Junction code: Setpoint of each program parameter
9. Draw the program pattern.

Example of Chart Entries

Starting target setpoint 1 (SSP1)	6	25°C
Starting target setpoint 2 (SSP2)		
Start code (STC)	7	0
1st group of wait zones (1.WZ1)		
1st group of wait times (1.WTM)		
2nd group of wait zones (2.WZ1)		
2nd group of wait times (2.WTM)		
3rd group of wait zones (3.WZ1)		
3rd group of wait times (3.WTM)		
4th group of wait zones (4.WZ1)		
4th group of wait times (4.WTM)		
5th group of wait zones (5.WZ1)		
5th group of wait times (5.WTM)		
Number of repetitions (RCY)		
Start-of-repetition segment number (RST)		
End-of-repetition segment number (REN)		

Define this parameter when using the controller as a program pattern generator. See User's Manual (Reference) (CD-ROM version) for more information.

See User's Manual (Reference) (CD-ROM version) for more information.

Program time unit (TMU)	4	Hour, minute
Segment setting method (SEG.T)	5	Time setting

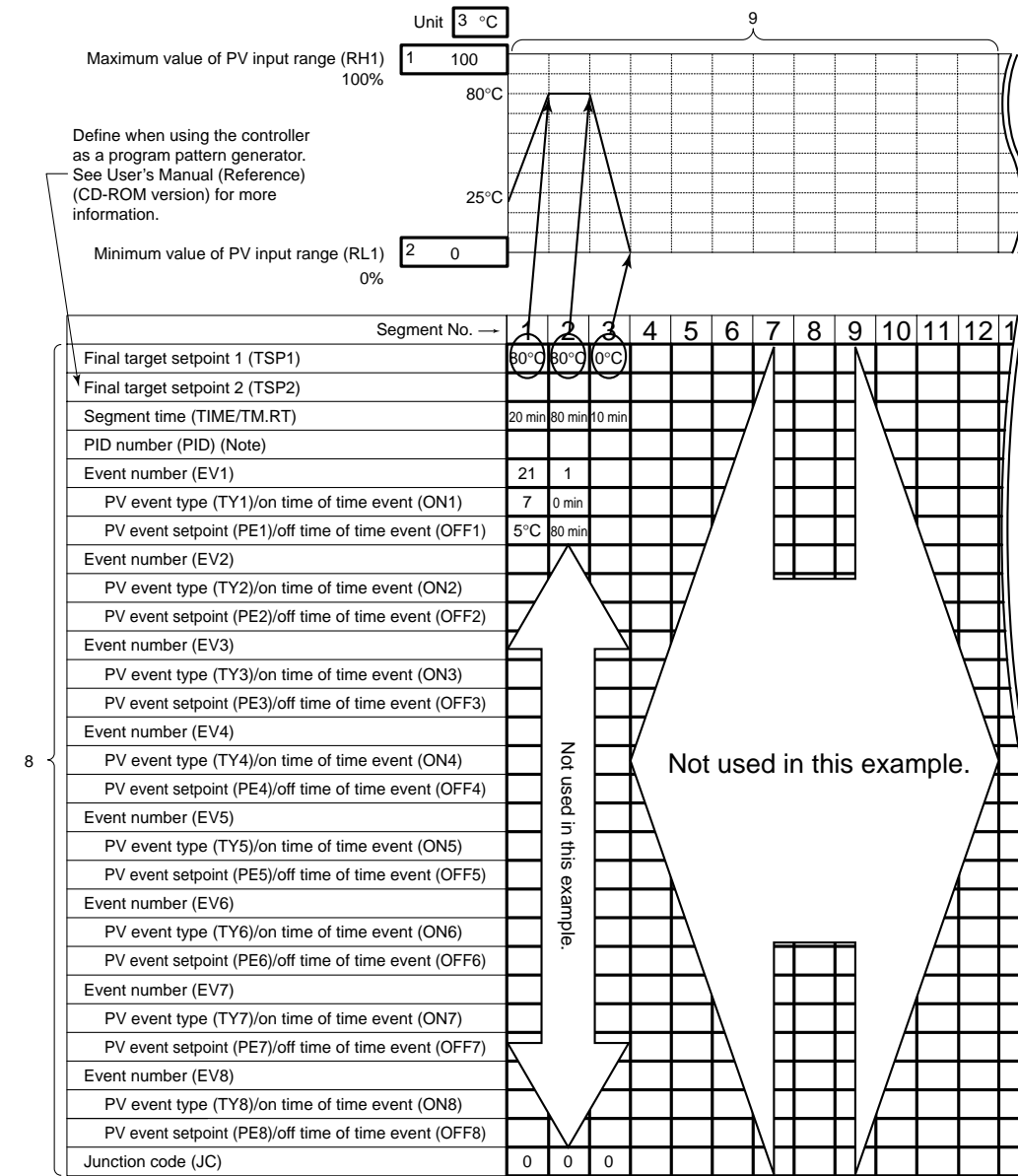

(Note) This parameter is shown for segment PID parameters when the setup parameter "ZON" is set to 0.

3. Creating Program Patterns

The following operating procedure describes an example of creating the program discussed in "1. Overview of Program Patterns."

NOTE

Before creating the program, reverify the Maximum Value of PV Input Range (RH1), Minimum Value of PV Input Range (RL1), Program Time Unit (TMU), and Segment Setting Method (SEG.T) parameters. If the setting of the setup parameter "SEG.T" is changed, the program patterns created and stored so far will be all cleared (initialized)!! Be careful.

The programming example given in this manual includes the following steps.

- Step 5 selects the program pattern number (PTN).
- Steps 7 to 9 configure the parameter Starting Target Setpoint (SSP1) (so that the program starts from 25°C).
- Steps 11 to 13 configure the Final Target Setpoint (TSP1) parameter for segment 1.
- Steps 14 to 16 configure the Segment Time (TIME) parameter for segment 1.
- Steps 17 to 25 configure the PV Event parameters (EV1, TY1 and PE1).
- Step 28 configures the Final Target Setpoint (TSP1) parameter for segment 2 (not changed in this example).
- Steps 29 to 31 configure the Segment Time (TIME) parameter for segment 2.
- Steps 32 to 40 configure the Time Event parameters (EV1, ON1 and OFF1).
- Steps 43 to 45 configure the Final Target Setpoint (TSP1) parameter for segment 3.
- Steps 46 to 48 configure the Segment Time (TIME) parameter for segment 3.

1. Bring the operating display into view (appears at power-on).
2. Press the **PROG** key for more than 3 seconds to call up the main menu "PROG".
3. Press the **LOC** key once to display the submenu "LOC".
4. Press the **PRG** key once to display the submenu "PRG".
5. Press the **PTN** key once to display the Pattern Number parameter "PTN". At this point, the PV display shows "01.00" (the first two digits denote the pattern number and the last two digits the segment number).
6. Press the **SEG** key once to display the Segment Number parameter "SEG".
7. Press the **SSP** key once to display the Starting Target Setpoint parameter "SSP1".
8. Press the **SP** key once to display the required setpoint.
9. Press the **SSP** key once to register the setpoint.
10. Press the **STC** key once to display the Start Code parameter "STC".
11. Press the **TSP** key once to display the Target Setpoint parameter "TSP1" for segment 1. At this point, the PV display shows "01.01" (the first two digits denote the pattern number and the last two digits the segment number).
12. Press the **TSP** key once to display the required setpoint.
13. Press the **TSP** key once to register the setpoint.
14. Press the **TIME** key once to display the Segment Time parameter "TIME" for segment 1.
15. Press the **TIME** key once to display the required setpoint.
16. Press the **TIME** key once to register the setpoint.
17. Press the **EV** key once to display the Event Number parameter "EV1".
18. Press the **EV** key once to display the required setpoint.
19. Press the **EV** key once to register the setpoint.
20. Press the **TY** key once to display the PV Event Type parameter "TY1".
21. Press the **TY** key once to display the required setpoint.
22. Press the **TY** key once to register the setpoint.
23. Press the **PE** key once to display the PV Event Setpoint parameter "PE1".
24. Press the **PE** key once to display the required setpoint.
25. Press the **PE** key once to register the setpoint.
26. Press the **EV** key once to display the Event Number parameter "EV2".
27. Press the **JC** key once to display the Junction Code parameter "JC" for segment 1. The setpoint of this parameter is not changed in this example.
28. Press the **TSP** key once to display the Target Setpoint parameter "TSP1" for segment 2. The setpoint of this parameter is not changed in this example. At this point, the PV display shows "01.02" (the first two digits denote the pattern number and the last two digits the segment number).
29. Press the **TIME** key once to display the Segment Time parameter "TIME" for segment 2.
30. Press the **TIME** key once to display the required setpoint.
31. Press the **TIME** key once to register the setpoint.
32. Press the **EV** key once to display the Event Number parameter "EV1".
33. Press the **EV** key once to display the required setpoint.
34. Press the **EV** key once to register the setpoint.
35. Press the **ON** key once to display the On Time of Time Event parameter "ON1".
36. Press the **ON** key once to display the required setpoint.
37. Press the **ON** key once to register the setpoint.

38. Press the **[OFF]** key once to display the Off Time of Time Event parameter "OFF1".

39. Press the **[OFF]** or **[ON]** key to display the required setpoint. The figure below shows an example of the parameter set to "1 hr. and 20 min. (setpoint 1h20)".

40. Press the **[OFF]** key once to register the setpoint.

41. Press the **[OFF]** key once to display the Event Number parameter "EV2".

42. Press the **[OFF]** key once to display the Junction Code parameter "JC" for segment 2. The setpoint of this parameter is not changed in this example.

43. Press the **[OFF]** key once to display the Target Setpoint parameter for segment 3. At this point, the PV display shows "01.03" (the first two digits denote the pattern number and the last two digits the segment number).

44. Press the **[OFF]** or **[ON]** key to display the required setpoint. The figure below shows an example of the parameter set to "0.0°C".

45. Press the **[OFF]** key once to register the setpoint.

46. Press the **[OFF]** key once to display the Segment Time parameter "TIME" for segment 3.

47. Press the **[OFF]** or **[ON]** key to display the required setpoint. The figure below shows an example of the parameter set to "10 min. (setpoint 0h10)".

48. Press the **[OFF]** key once to register the setpoint.

49. Programming is now complete. Press the **[OFF]** key for more than 3 seconds. This returns you to the display shown at power-on (figure below).

4. Changing Program Patterns

The following operating procedure describes an example of changing the program pattern created in "3. Creating Program Patterns" to the program pattern shown in the figure below.

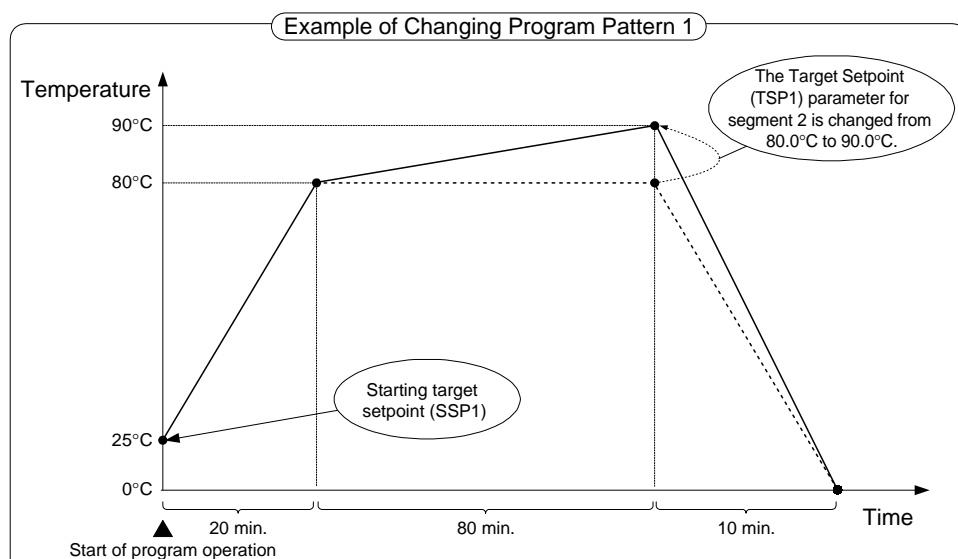

Details of the Change

- Before change: Program operation begins with the starting target setpoint (SSP1).
After change: Program operation begins with the current PV value. The time setpoints of segment 1 precede others.
- Change the setpoint of the Start Code (STC) program parameter to "2".
- Before change: The Target Setpoint (TSP1) program parameter for segment 2 was set to "80.0°C".
After change: The Target Setpoint (TSP1) program parameter for segment 2 is set to "90.0°C".
- Change the setpoint of the Target Setpoint (TSP1) program parameter for segment 2 to "90.0°C".

- Bring the operating display into view (appears at power-on).
The figure below shows an example of the parameter set to "time-prioritized PV start (setpoint 2)".
- Press the **[OFF]** key for more than 3 seconds to call up the main menu "PROG".
- Press the **[OFF]** key once to display the submenu "LOC".
- Press the **[OFF]** key once to display the submenu "PRG".
- Press the **[OFF]** key once to display the Pattern Number parameter "PTN".
- Press the **[OFF]** key once to display the Segment Number parameter "SEG".
- Press the **[OFF]** key twice to display the Start Code parameter "STC".
- Press the **[OFF]** or **[ON]** key to display the required setpoint. The figure below shows an example of the parameter set to "90.0°C".
- Press the **[OFF]** key once to register the setpoint.
- Press the **[OFF]** key seven times to display the Target Setpoint parameter "TSP1" for segment 2. At this point, the PV display shows "01.02" (the first two digits denote the pattern number and the last two digits the segment number).
- Press the **[OFF]** or **[ON]** key to display the required setpoint. The figure below shows an example of the parameter set to "0.0°C".
- Press the **[OFF]** key once to register the setpoint.
- Press the **[OFF]** or **[ON]** key to display the required setpoint. The figure below shows an example of the parameter set to "90.0°C".
- Press the **[OFF]** key once to register the setpoint.
- Changing the program is now complete. Press the **[OFF]** key for more than 3 seconds. This returns you to the display shown at power-on (figure below).

Error Indication at Program Pattern Creation and Editing

Error code	Error information	Cause of error
0	No error	Normal end
01	Pattern creation or editing is disable during program or local operation.	Adding, deleting, or copying of the program pattern, segment, or event was executed during program or local operation.
02	Pattern number error Only when using communication (The error code is stored in register B0005.)	The specified pattern number does not exist. Pattern numbers : 1 to 30
03	Segment number error Only when using communication (The error code is stored in register B0105.)	The specified segment number does not exist. Segment numbers : 1 to 99
11	Pattern information read error Only when using communication (The error code is stored in register B0005.)	Pattern read was attempted during pattern read. Pattern read was executed when the parameters in "PRG" and "EDIT" program parameter submenus are displayed on the LCD.
12	Pattern information write error Only when using communication (The error code is stored in register B0005.)	Pattern write was attempted during pattern write. Pattern write was executed when the parameters in "PRG" and "EDIT" program parameter submenus are displayed on the LCD.
21	Segment read error Only when using communication (The error code is stored in register B0105.)	Segment read was attempted during pattern read. Segment read was executed when the parameters in the "PRG" and "EDIT" program parameter submenus are displayed on the LCD.
22	Segment write error Only when using communication (The error code is stored in register B0105.)	The total number of segments exceeded 300.
23	Segment insert error	During program operation, the total number of segments exceeded 300 or numbers in a pattern exceeded 99, and therefore a new segment cannot be register or added. The specified segment is missing.
24	Segment delete error	Any segment cannot be deleted during program operation. The specified segment is missing.
25	Exceeded segment count error	The number of segments exceeded 300.
31	Pattern copy error Only when using communication (The error code is stored in register B0005.)	No pattern is present at the source or program operation is being executed when the source of pattern copy is specified.
32	Pattern source specification error	Patterns already exist at the destination.
33	Pattern destination specification error	Patterns already exist at the destination.
41	Pattern delete error	At pattern delete operation, specified pattern does not exist or program operation is being executed.
51	Event write error Only when using communication (The error code is stored in register B0105.)	The number of events exceeded 400. Or the number of remaining events is less than 8. (Write is disabled when remaining settable events are less than 8)

Operation Modes

The UP550 has the following four types of operation modes:

- RUN (program operation start) mode
- HOLD (program operation hold) mode
- LOCAL (local operation) mode
- RESET (program operation stop) mode

The operation modes switching function and the control state for each mode are described below.

Operation Modes Switching Function

Operation modes RUN, HOLD, LOCAL, and RESET can be switched as described below.

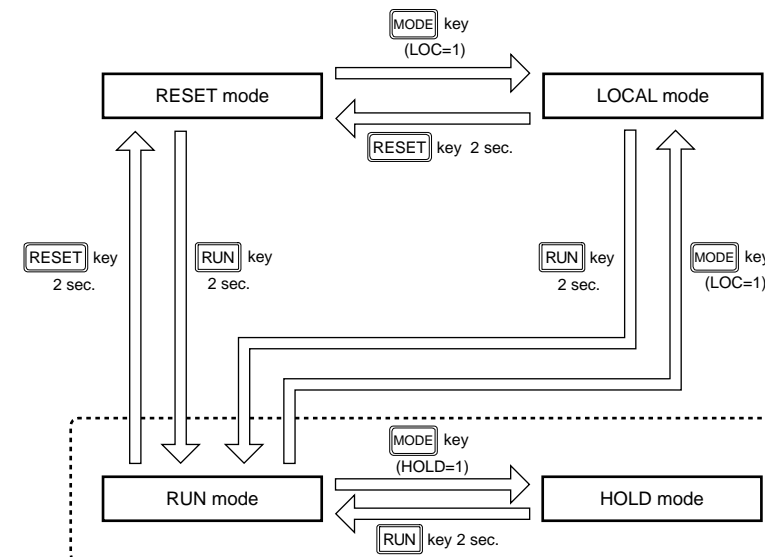

RUN (program operation start) mode

The controller executes the control operation using the program pattern.

Pressing the **[RUN]** key on the controller's front panel starts a control operation using the selected program pattern, which can also be started by means of an external contact input or communication. The PRG indicator lamp on the front panel is lit in RUN mode.

Auto-tuning Function

The auto-tuning function is used to have the controller measure process characteristics and automatically set the most appropriate PID constant. This function cannot be used for on/off control. As the function is started, control outputs are temporarily varied in steps and the responses are used for computing the proper PID constant - this is called a limited-cycle method.

The auto-tuning function should not be applied to the following processes:

- Control processes with quick response such as flow control or pressure control
- Processes where even temporary output on/off results in inconvenience
- Processes where a large output change at control element results in inconvenience
- Processes where variations in PV may exceed an allowable range, adversely affecting product quality.

Operating parameter AT

Description	Setpoint	TIP
Disable auto-tuning	OFF	Factory-set default
Perform auto-tuning on the specified PID group	1 to 8	When PID setpoint is switched using segment-PID, setpoints 1 to 8 are not effective.
Perform auto-tuning to all PID groups	9	Only available for zone-PID

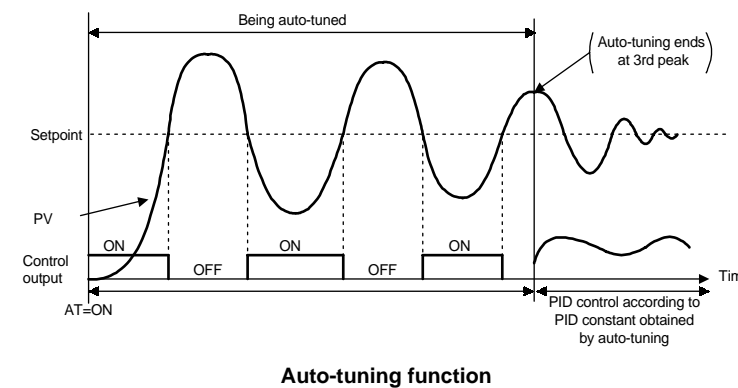

Auto-tuning in Segment-PID Control

When auto-tuning is performed for segment-PID, the most proper PID constant can be obtained for the current target setpoint. The obtained PID constant is saved to the set PID constant parameter. When PID number 2 is set for segment 1 and AT=1 is executed, for example, obtained PID constant is saved as PID number 2.

- The auto-tuning parameter (AT) setpoints, its corresponding tuning point, and the tuned PID group number for "segment-PID" control (zone-PID selection parameter ZON is set at "0") are:

AT setpoints	Tuning point (SP at which auto-tuning is performed)	Tuned PID group number
1	Current target setpoint (SP) at the starting of auto-tuning	PID number assigned for the segment being used.
2		
3		
4		
5		
6		
7		
8		

HOLD (program operation hold) mode

The controller temporarily interrupts the program operation.

Pressing the **[MODE]** key on the front panel temporarily interrupts the program operation, which can also be interrupted by means of an external contact input or communication. The HLD indicator lamp on the front panel is lit in Hold mode.

RESET (program operation stop) mode

The controller stops the program operation.

Pressing the **[RESET]** key on the front panel stops the program operation, which can also be stopped by means of an external contact input or communication. The RST indicator lamp on the front panel is lit in RESET mode, and all event functions are turned off.

LOCAL (local operation) mode

The controller executes the local control operation.

Selecting the LOCAL operation using the **[MODE]** key on the front panel starts the local control operation, which can also be started by means of an external contact input or communication. The LOC indicator lamp on the front panel is lit in LOCAL mode.

Control Status

The control status of each operation mode for UP550 is described below.

Operation Mode and Control Status			
Operation mode	Target setpoint	Control output	Applicable key operation
RESET	0%	Preset output.	<ul style="list-style-type: none"> • Program pattern selection • Program operation starting • Local operation starting • LSP modification • Output value modification (in MAN mode)
LOCAL	Setpoint for local-mode operation (LSP)	AUTO: Result of control computation. MAN: Manipulated output.	<ul style="list-style-type: none"> • RESET of operation • Program operation starting • Output value modification (in MAN mode) • RESET of operation • LOCAL operation starting • HOLD mode
RUN	Target setpoint for each segment	AUTO: Result of control computation. MAN: Manipulated output.	<ul style="list-style-type: none"> • Output value modification (in MAN mode) • RESET of operation • LOCAL operation starting • HOLD mode
HOLD	Setpoint when the mode is changed to HOLD, or setpoint in HOLD mode modified by key operation in the case of soak segment.	AUTO: Result of control computation. MAN: Manipulated output.	<ul style="list-style-type: none"> • Segment remaining time modification (in the case of soak segment) • RESET of operation • LOCAL operation starting • Program operation starting

Auto-tuning in Zone-PID Control

When auto-tuning is performed for zone-PID with the parameter AT set between 1 and 8, the optimum PID constants are obtained by using the current target setpoint value at the start of auto-tuning as a tuning point. The obtained PID values are saved as PID parameters for the PID number of the specified auto-tuning number. For example, if AT=2 is executed in zone 1, which is controlled with 1.PID parameters, the obtained PID constants will be saved as 2.PID parameters.

On the other hand, when auto-tuning is performed with parameter AT=9, the optimum PID constants for all the group numbers in use are obtained automatically, using the median value of each set reference point as tuning point. For example, the following points will be the tuning points.

- Median value of "the minimum value of PV input range" and "reference point 1"
- Median value of "reference point 1" and "reference point 2"
- Median value of "reference point 2" and "the maximum value of PV input range"

Since auto-tuning is performed progressively by processing to successive reference points, reference points 2 to 6 should be set so that the temperature during auto-tuning does not rise above the maximum limit for the controlled process. If there are any unused reference points, set them at the same value as the maximum value of the PV input range.

In heating/cooling control, when a certain zone is set for on/off control (proportional band parameter, n.P or n.Pc, is set at "0") however, auto-tuning skips that zone and proceeds to the next zone.

When controlling equipment such as heating furnaces, the PV input range must be set at a proper value (for example, setting room-temperature as the minimum value) when:

- The gap between reference point 1 and the minimum value of PV input range is large.
- The gap between the top reference point and the maximum value of the PV input range is large.

The figure below is the example of setting two reference points.

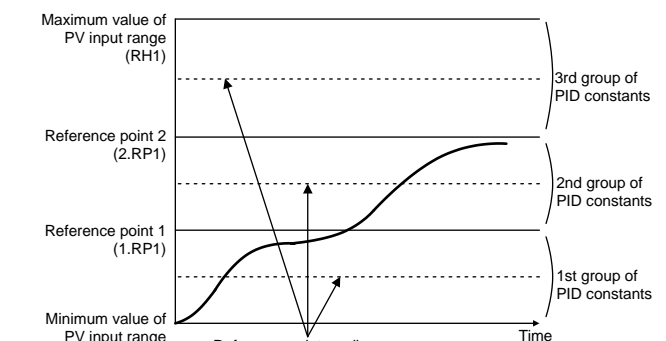

Auto-tuning in Zone-PID Control (when AT=9)

- The auto-tuning parameter (AT) setpoints, corresponding tuning points and tuned PID group numbers for "zone-PID" control (zone-PID selection parameter ZON is set at "1") are:

AT setpoints	Tuning point (SP at which auto-tuning is performed)	Tuned PID group number
1	Current target setpoint (SP) at the starting of auto-tuning	1
2	Current target setpoint (SP) at the starting of auto-tuning	2
3	Current target setpoint (SP) at the starting of auto-tuning	3
4	Current target setpoint (SP) at the starting of auto-tuning	4
5	Current target setpoint (SP) at the starting of auto-tuning	5
6	Current target setpoint (SP) at the starting of auto-tuning	6
7	Current target setpoint (SP) at the starting of auto-tuning	7
8	Current target setpoint (SP) at the starting of auto-tuning	8
9 (AUTO)	Median of each zone	1 to 8

This manual briefly explains the functions of program parameters. In addition, it contains a program pattern setup chart. Completely fill in the chart before you set a program in the UP550 program controller.

Contents

1. Program Pattern Setup Charts
2. Program Parameter Map
3. Lists of Program Parameters
4. Explanation of Program Functions

1. Program Pattern Setup Charts

For details on how to use the program pattern setup chart, see "1. Overview of Program Patterns" and "2. Example of Program Pattern Setup Charts" in *Programming User's Manual*. You can register as many as 30 program patterns with the UP550 controller. Create as many copies of the chart as necessary. First fill in the fields with bold-face borders in the order from number 1 to number 9. Then, input the data into the controller.

1. Maximum value of PV input range: Setpoint of the "Maximum Value of PV Input Range (RH1)" setup parameter
2. Minimum value of PV input range: Setpoint of the "Minimum Value of PV Input Range (RL1)" setup parameter
3. PV input unit: Setpoint of the "PV Input Unit (UNI)" setup parameter
4. Program time unit: Setpoint of the "Program Time Unit (TMU)" setup parameter
5. Segment setting method: Setpoint of the "Segment Setting Method (SEG.T)" setup parameter
6. Starting target setpoint: Setpoint of the "Starting Target Setpoint (SSP1)" program parameter
7. Start code: Setpoint of the "Start Code (STC)" program parameter
8. Final target setpoint, Segment time, Events (PV event and Time event), and Junction code: Setpoint of each program parameter
9. Draw the program pattern.

Starting target setpoint 1 (SSP1)	6
Starting target setpoint 2 (SSP2)	
Start code (STC)	7
1st group of wait zones (1.WZ1)	
1st group of wait times (1.WTM)	
2nd group of wait zones (2.WZ1)	
2nd group of wait times (2.WTM)	
3rd group of wait zones (3.WZ1)	
3rd group of wait times (3.WTM)	
4th group of wait zones (4.WZ1)	
4th group of wait times (4.WTM)	
5th group of wait zones (5.WZ1)	
5th group of wait times (5.WTM)	
Number of repetitions (RCY)	
Start-of-repetition segment number (RST)	
End-of-repetition segment number (REN)	

Define this parameter when using the controller as a program pattern generator. See User's Manual (Reference) (CD-ROM version) for more information.

See User's Manual (Reference) (CD-ROM version) for more information.

System name	
Program No.	
Program name	
Model	UP550 -
Serial No.	
Program time unit (TMU)	4
Segment setting method (SEG.T)	5

Unit	3	9
Maximum value of PV input range (RH1)	1	100%
Minimum value of PV input range (RL1)	2	0%

Define this parameter when using the controller as a program pattern generator. See User's Manual (Reference) (CD-ROM version) for more information.

Time setting (TIME) when the Segment Setting Method (SEG.T) parameter is set as SEG.T = 0; ramp setting (TR.RT) when the parameter is set as SEG.T = 1. Factory-set to Time setting (TIME).

Shown for segment PID parameters when the setup parameter "ZON" is set to 0.

Segment No.	1	2	3	4	5	6	7	8	9	10	11	12	13	14	15	16	17	18	19	20
Final target setpoint 1 (TSP1)																				
Final target setpoint 2 (TSP2)																				
Segment time (TIME/TM.RT)																				
PID number (PID)																				
Event number (EV1)																				
PV event type (TY1)/on time of time event (ON1)																				
PV event setpoint (PE1)/off time of time event (OFF1)																				
Event number (EV2)																				
PV event type (TY2)/on time of time event (ON2)																				
PV event setpoint (PE2)/off time of time event (OFF2)																				
Event number (EV3)																				
PV event type (TY3)/on time of time event (ON3)																				
PV event setpoint (PE3)/off time of time event (OFF3)																				
Event number (EV4)																				
PV event type (TY4)/on time of time event (ON4)																				
PV event setpoint (PE4)/off time of time event (OFF4)																				
Event number (EV5)																				
PV event type (TY5)/on time of time event (ON5)																				
PV event setpoint (PE5)/off time of time event (OFF5)																				
Event number (EV6)																				
PV event type (TY6)/on time of time event (ON6)																				
PV event setpoint (PE6)/off time of time event (OFF6)																				
Event number (EV7)																				
PV event type (TY7)/on time of time event (ON7)																				
PV event setpoint (PE7)/off time of time event (OFF7)																				
Event number (EV8)																				
PV event type (TY8)/on time of time event (ON8)																				
PV event setpoint (PE8)/off time of time event (OFF8)																				
Junction code (JC)																				

2. Program Parameter Map

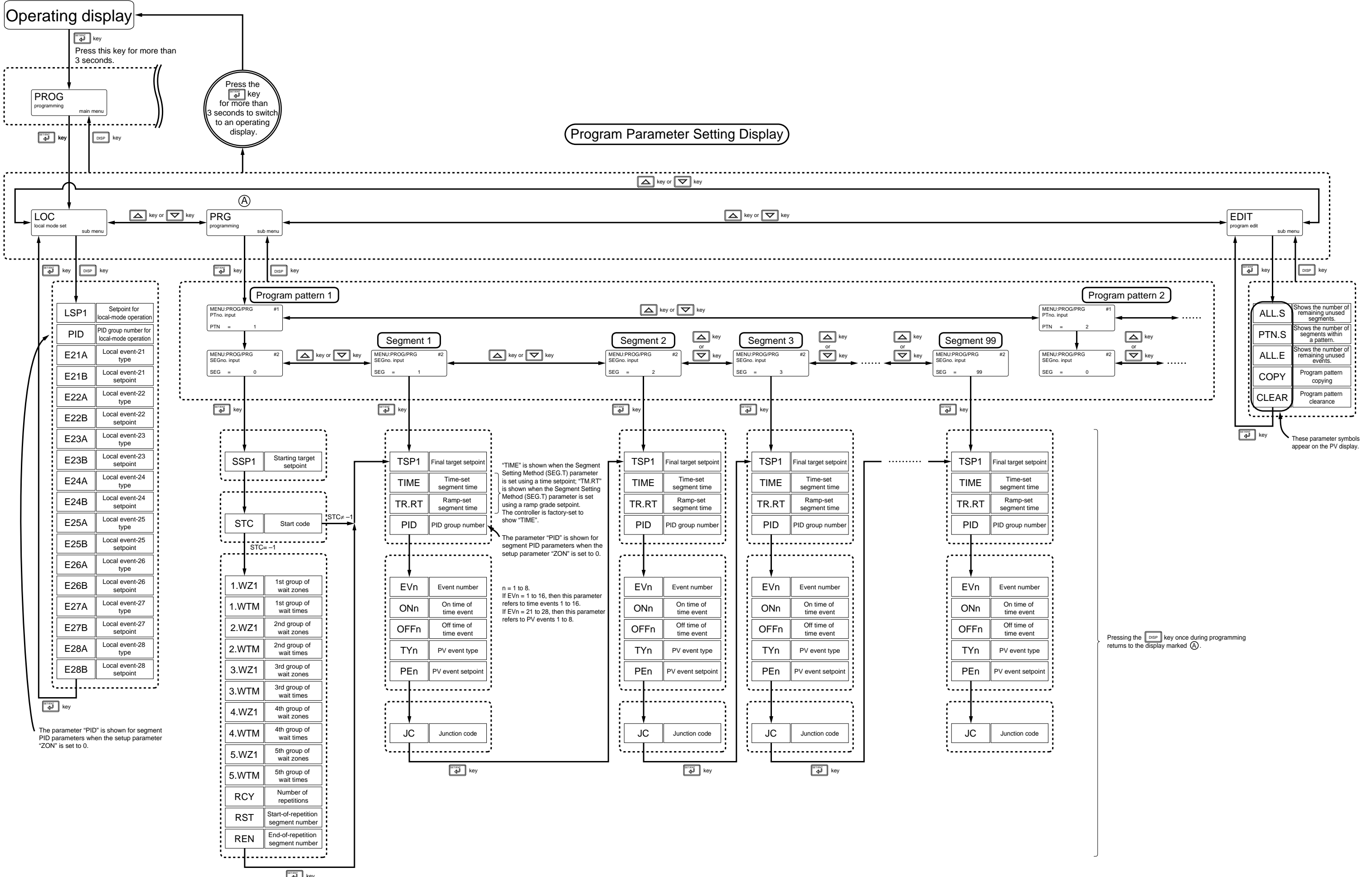

3. Lists of Program Parameters

Local Setpoint Parameters

Located in: Main menu = PROG ; Submenu = LOC

Parameter Symbol	Name of Parameter	Setting Range and Description	Initial Value	User Setting	Target Item in CD-ROM
LSP1	Setpoint for local-mode operation	0.0 to 100.0% of PV input range	0.0% of PV input range		
PID	PID group number for local-mode operation	Shown for segment PID parameters when the setup parameter "ZON" is set to 0. This parameter is factory-set so as not to appear. 1: Uses the 1st group of PID parameters. 2: Uses the 2nd group of PID parameters. 3: Uses the 3rd group of PID parameters. 4: Uses the 4th group of PID parameters. 5 to 8: Likewise, selecting these numbers uses the 5th to 8th groups of PID parameters.	1		
E21A	Local event-21 type	OFF, 1 to 10, 28 to 31 1: PV high limit (energized, no stand-by action) 2: PV low limit (energized, no stand-by action) 3: Deviation high limit (energized, no stand-by action) 4: Deviation low limit (energized, no stand-by action) 5: Deviation high limit (de-energized, no stand-by action) 6: Deviation low limit (de-energized, no stand-by action) 7: Deviation high/low limits (energized, no stand-by action) 8: Deviation within high/low limits (energized, no stand-by action) 9: PV high limit (de-energized, no stand-by action) 10: PV low limit (de-energized, no stand-by action) See Parameter Map User's Manual for details on other alarm types.	OFF		
E21B	Local event-21 setpoint	PV/SP alarm: -100.0 to 100.0% of PV input range Deviation alarm: -100.0 to 100.0% of PV input range span Output value alarm: -5.0 to 105.0%	PV/SP high limit alarm: 100.0% of PV input range. Deviation alarm: 0.0% of PV input range span. Other PV/SP low limit alarms: 0.0% of PV input range. Output high limit alarm: 100.0% Output low limit alarm: 0.0%		Ref.5.2(9)
E22A	Local event-22 type	Same as the E21A parameter.			
E22B	Local event-22 setpoint	Same as the E21B parameter.			
E23A	Local event-23 type	Same as the E21A parameter.			
E23B	Local event-23 setpoint	Same as the E21B parameter.			
E24A	Local event-24 type	Same as the E21A parameter.			
E24B	Local event-24 setpoint	Same as the E21B parameter.			
E25A	Local event-25 type	Same as the E21A parameter.			
E25B	Local event-25 setpoint	Same as the E21B parameter.			
E26A	Local event-26 type	Same as the E21A parameter.			
E26B	Local event-26 setpoint	Same as the E21B parameter.			
E27A	Local event-27 type	Same as the E21A parameter.			
E27B	Local event-27 setpoint	Same as the E21B parameter.			
E28A	Local event-28 type	Same as the E21A parameter.			
E28B	Local event-28 setpoint	Same as the E21B parameter.			

Program Parameters (Parameters for Setting the Conditions of Program Operation Startup)

Use the program pattern setup chart discussed in "I. Program Pattern Setup Charts" of this manual, to record your setpoints of program parameters.

Located in: Main menu = PROG ; Submenu = PRG

Parameter Symbol	Name of Parameter	Setting Range and Description	Initial Value	User Setting	Target Item in CD-ROM
PTN	Pattern number	1: Program pattern 1 2: Program pattern 2 3: Program pattern 3 4 to 30: Likewise, specifying these numbers sets their corresponding program pattern numbers.			—
SEG	Segment number	0: Shows parameters for setting the starting target setpoint, start code, etc. 1 to 99: Specify the corresponding segment numbers. Specify "0" when creating a program for the first time.	0		—
SSP1	Starting target setpoint	0.0 to 100.0% of PV input range	0.0% of PV input range		
STC	Start code	-1: Shows parameters for setting the wait and repeat actions. 0: Program operation begins with the starting target setpoint. 1: Ramp-prioritized PV start (program operation begins with the PV value by giving priority to the ramp of segment 1) 2: Time-prioritized PV start (program operation begins with the PV value by giving priority to the time of segment 1) TIP: The option "-1" is not a setpoint.	0		Ref.5.2(1)

Program Parameters (Parameters for Setting the Wait and Repeat Actions)

The parameters listed below are shown when the Start Code (STC) parameter is set to "-1".

Located in: Main menu = PROG ; Submenu = PRG

Parameter Symbol	Name of Parameter	Setting Range and Description	Initial Value	User Setting	Target Item in CD-ROM
1.WZ1	1st group of wait zones	OFF: No function 0.0 to 10.0% of PV input range span	OFF		
1.WTM	1st group of wait times	OFF: No function 0.01 to 99.59 ("hour, minute" or "minute, second") Use the TMU setup parameter to set the time unit.	OFF		
2.WZ1	2nd group of wait zones	Same as the 1st group of wait zones.			
2.WTM	2nd group of wait times	Same as the 1st group of wait times.			
3.WZ1	3rd group of wait zones	Same as the 1st group of wait zones.			
3.WTM	3rd group of wait times	Same as the 1st group of wait times.			
4.WZ1	4th group of wait zones	Same as the 1st group of wait zones.			
4.WTM	4th group of wait times	Same as the 1st group of wait times.			
5.WZ1	5th group of wait zones	Same as the 1st group of wait zones.			
5.WTM	5th group of wait times	Same as the 1st group of wait times.			
RCY	Number of repetitions	0 to 999: The controller repeats the segment specified by the RST and REN parameters as many times as defined by this parameter. CONT: The controller indefinitely repeats the segment specified by the RST and REN parameters.	0		
RST	Start-of-repetition segment number	1 to 99	1		
REN	End-of-repetition segment number	1 to 99	1		

* Parameters relating to PV or program setpoints should all be set in real numbers. For example, use temperature values to define program setpoints and PV event setpoints for temperature input.

* The "User Setting" column in the table below is provided for the customer to record setpoints.

* The "Target Item in CD-ROM" column in the table below provided references from User's Manual (Reference) (CD-ROM version) which describes items in more detail and items that are not contained in this manual.

Program Parameters (Parameters for Setting the Final Target Setpoints and Segment Times)

Located in: Main menu = PROG ; Submenu = PRG

Parameter Symbol	Name of Parameter	Setting Range and Description	Initial Value	User Setting	Target Item in CD-ROM
TSP1	Final target setpoint	The final target setpoint of each segment.			
TIME	Time-set segment time	Time setpoint: - (unregistered) 0.00 to 99.59 ("hour, minute" or "minute, second") Without a time setpoint, it is not possible to create programs.			Ref.5.1(1)
TM.RT	Ramp-set segment time	For ramp segments (ramp setpoint): - (unregistered), 0.0 to 100.0% of PV input range span per hour or minute For soak segments (time setpoint): 0.00 to 99.59 ("hour, minute" or "minute, second") Without a time setpoint or a ramp grade setpoint, it is not possible to create programs.			
PID	Segment PID group number	This parameter is shown for segment PID parameters when the setup parameter "ZON" is set to 0. This parameter is factory-set so as not to appear. 1 to 8	1		Ref.5.1(2)

Program Parameters (Parameters for Setting the Event Action)

You can set a maximum of eight units each for the parameters listed below for each individual segment.

Located in: Main menu = PROG ; Submenu = PRG

Parameter Symbol	Name of Parameter	Setting Range and Description	Initial Value	User Setting	Target Item in CD-ROM
EVn	Event number	0: Unregistered. 1: Time event 1 (terminal numbers ①-⑨) 2: Time event 2 (terminal numbers ⑩-⑱) 3: Time event 3 (terminal numbers ⑲-⑳) 4: Time event 4 (terminal numbers ㉑-㉒) 5 to 16: Time events 5 to 16 (see the CD-ROM version user's manual for details on the terminal number) 21: PV event 1 (terminal numbers ㉓-㉔) 22: PV event 2 (terminal numbers ㉕-㉖) 23 to 28: PV events 3 to 8 (see the CD-ROM version user's manual for details on the terminal number)	0		Ref.3.4(5) Ref.3.4(6)
ONn	On time of time event	OFF: Unused. 0.00 to 99.59 ("hour, minute" or "minute, second")	OFF		
OFFn	Off time of time event	OFF: Unused. 0.00 to 99.59 ("hour, minute" or "minute, second")	OFF		Ref.3.4(6)
TYn	PV event type	OFF, 1 to 10, 28 to 31 1: PV high limit (energized, no stand-by action) 2: PV low limit (energized, no stand-by action) 3: Deviation high limit (energized, no stand-by action) 4: Deviation low limit (energized, no stand-by action) 5: Deviation high limit (de-energized, no stand-by action) 6: Deviation low limit (de-energized, no stand-by action) 7: Deviation high/low limits (energized, no stand-by action) 8: Deviation within high/low limits (energized, no stand-by action) 9: PV high limit (de-energized, no stand-by action) 10: PV low limit (de-energized, no stand-by action) See Parameter Map User's Manual for details on other alarm types.	OFF		
PEn	PV event setpoint	PV/SP alarm: -100.0 to 100.0% of PV input range Deviation alarm: -100.0 to 100.0% of PV input range span Output value alarm: -5.0 to 105.0%	PV/SP high limit alarm: 100.0% of PV input range. Other PV/SP low limit alarms: 0.0% of PV input range. Output high limit alarm: 100.0% Output low limit alarm: 0.0%		Ref.3.4(5)

Program Parameters (Junction Code Parameter)

Located in: Main menu = PROG ; Submenu = PRG

Parameter Symbol	Name of Parameter	Setting Range and Description	Initial Value	User Setting	Target Item in CD-ROM
JC	Junction code	The junction code (JC) basically used to specify the condition for moving from one segment to the next and the intra-segment operating condition. 0: Switching for continuation 1: Hold-on switching (the controller holds the end-of-segment setpoint when the segment is completed, to perform control). 2: Local-mode end (the controller switches to a local setpoint when the segment is completed). 11 to 15: Wait during switching between segments (see the CD-ROM version user's manual). INSERT: Allows a segment to be added to the end of a specified segment. DELETE: Allows a specified segment to be deleted. 101 to 130: Linked to patterns 1 to 30. For example, when setting "102" in JC of the final segment, the operation for pattern 2 is started after the end of pattern 1. - Notes at pattern-link > - Parameter STC is available. - PV event and time event are reset. - Parameter SST is not available.	0		Ref.5.2(3) Ref.5.2(4) Ref.5.3(6)

Program Parameters (Parameters for Editing Programs)

Located in: Main menu = PROG ; Submenu = EDIT

Symbol on PV display	Name of Parameter	Setting Range and Description	Initial Value	User Setting	Target Item in CD-ROM
ALLS (ALLS)	Number of remaining unused segments.	Read-only			Ref.5.3(1)
PTnS (PTN.S)	Number of segments within a pattern.				Ref.5.3(2)
ALLE (ALLE)	Number of remaining unused events.				Ref.5.3(3)
COPY (COPY)	Program pattern copying	Specify the numbers of the source-of-copying program pattern and target-of-copying program pattern. (1 to 30)			Ref.5.3(4)
CLEAR (CLEAR)	Program pattern clearance	Specify the number of the program pattern to be cleared. (1 to 30)			Ref.5.3(5)

4. Explanation of Program Functions

Programming

You can create programs using either method 1 or 2 described below. The controller is factory-set to "method 1". To create programs using method 2, change the setpoint of the SEG.T (Segment Setting Method) setup parameter to "1". Before you begin programming, determine whether your programs are created using the time unit of "hour and minute" or "minute and second." The controller is factory-set to the "hour and minute" time unit. To create programs using the "minute and second" time unit, change the setpoint of the TMU (Program Time Unit) setup parameter to "mm:ss".

Controller Settings

	Setpoint of SEG.T (Segment Setting Method) Setup Parameter
Time setting (method 1)	0 (factory-set default)
Ramp setting (method 2)	1

Choose the desired method and unit from the two programming methods and time unit options discussed above. Then, create programs according to the chosen options.

1. Creating programs by setting final target setpoint and segment time

As shown in the figure on the right, this method creates programs by setting a segment time and a final target setpoint on a segment-by-segment basis.

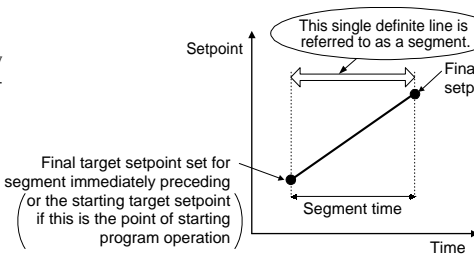

2. Creating programs by setting final target setpoint and ramp

As shown in the figure on the right, this method creates programs by setting a final target setpoint and a ramp grade on a segment-by-segment basis. Define the ramp grade as the amount of change in the setpoint per hour or per minute.

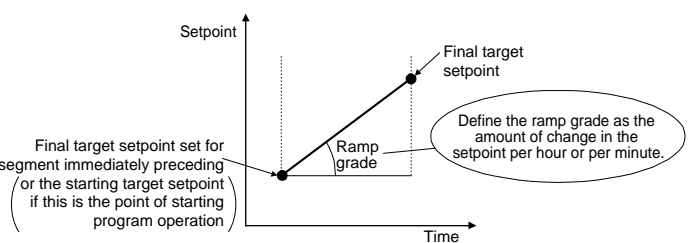

Controller Settings

	Setpoint of TMU (Program Time Unit) Setup Parameter
When changing the setpoint linearly over an hour	hh:mm (factory-set default)
When changing the setpoint linearly over a minute	mm:ss

Note: The "Program Time Unit (TMU)" parameter is the time unit you use when creating programs.

When creating a soak segment during programming, set a time ("hour and minute" or "minute and second") rather than a ramp grade.

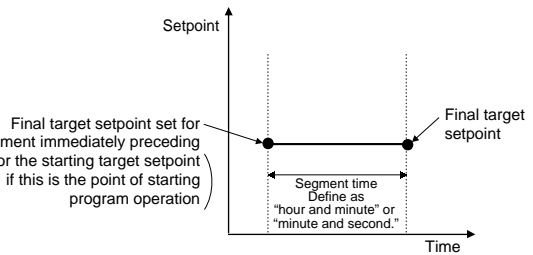

For example, configure segment 1 so the temperature rises in increments of 5°C per minute from 50°C to 100°C, as shown in the figure on the right.

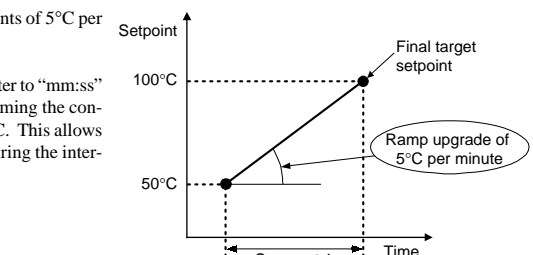

To change the temperature linearly over a minute, set the TMU parameter to "mm:ss" (minute and second) before you begin programming. When programming the controller, set the Segment Time (TMRT) parameter for segment 1 to 5". This allows the controller to raise the setpoint in increments of 5°C per minute during the interval of segment 1.

Controller Behavior at the Start of Program Operation

You can determine how the controller should behave at the start of program operation.

1. Letting the controller run from a starting target setpoint

A starting target setpoint refers to a setpoint from which program operation begins. The controller operates in such a manner that the setpoint changes to the final target setpoint over the segment time set for segment 1, irrespective of what the PV value is.

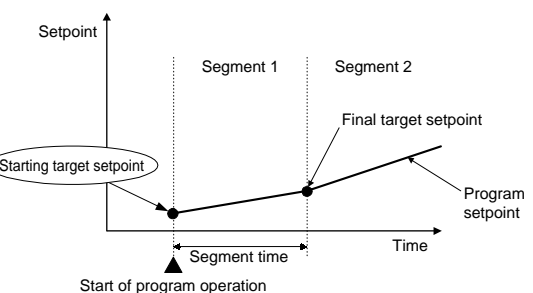

Controller Settings

Set the STC (Start Code) program parameter to "0".

2. Letting the controller start from the current setpoint and run according to time settings defined for segment 1

This method is not available if the SEG.T (Segment Setting Method) parameter is set to "ramp setting."

Starting Point of Operation	Controller Behavior
a	Begins to run from point a according to the time setting defined for segment 1.
b	Begins to run from point b according to the time setting defined for segment 1.
c	Begins to run from point c according to the time setting defined for segment 1.
d	Begins to run from point d according to the time setting defined for segment 1.
e	Begins to run from point e according to the time setting defined for segment 1.

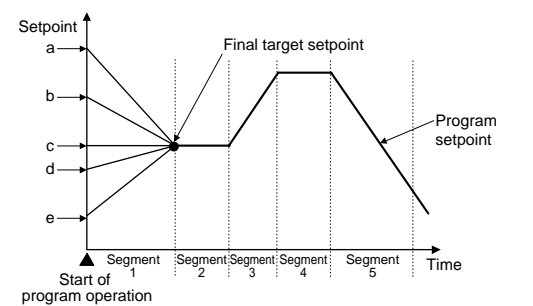

Controller Settings

Set the STC (Start Code) program parameter to "2".

3. Letting the controller start from the current setpoint and run according to ramp settings defined for segment 1

Starting Point of Operation	Controller Behavior
a	Begins to run from point C1 (ignores the time setting defined for segment 1).
b	Begins to run from point C1 (ignores the time setting defined for segment 1).
c	Begins to run from point C1 (ignores the time setting defined for segment 1).
d	Begins to run from point D1 according to the preset ramp setting (the time setting defined for segment 1 is reduced).
e	Begins to run from point E1 according to the preset ramp setting.

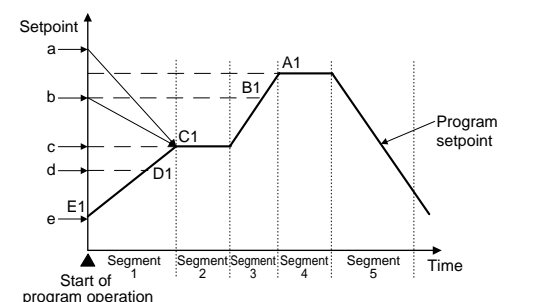

Controller Settings

Set the STC (Start Code) program parameter to "1".

PID Switching (Zone PID)

The UP550 offers two methods of PID switching. One of the methods is to automatically switch between groups of PID constants according to the temperature zone. The other method is to automatically switch between groups of PID constants on a segment-by-segment basis. This paragraph explains the method of switching between groups of PID constants according to the temperature zone. You can set a maximum of seven temperature zones. When shipped from the factory, the UP550 is configured so that it operates in zone 1 only and uses only one group of PID constants.

When One Group of PID Constants Is Used (factory-set default)

As shown in the figure on the right, the controller uses one group of PID constants over the range from the minimum value to the maximum value of the PV input range.

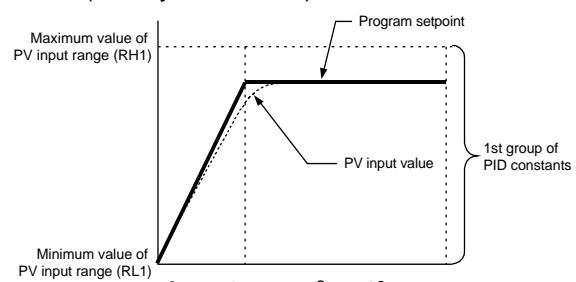

Controller Settings
- Configure the 1st group of PID constants (1.P, 1.1 and 1.D operating parameters).

Selection of PID Constants when the Control Range Is Split into Three Zones

As shown in the figure on the right, three zones are set for the controller to automatically switch from one group of PID constants to another. Two zones can also be set for the controller to switch between two groups of PID constants.

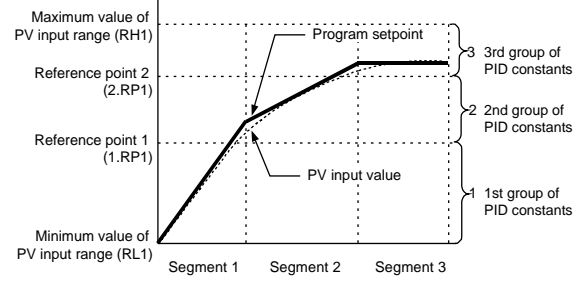

- The controller uses the 1st group of PID constants if the PV input value is within the zone set off by the minimum value of the PV input range and reference point 1.
- The controller uses the 2nd group of PID constants if the PV input value is within the zone set off by reference point 1 and reference point 2.
- The controller uses the 3rd group of PID constants if the PV input value is within the zone set off by reference point 2 and the maximum value of the PV input range.

Controller Settings

- Splitting the control range into two zones
 - To split the control range into two zones, define reference point 1 (i.e., the 1.RP1 setup parameter).
 - Define the 1st and 2nd groups of PID constants (i.e., the 1.P, 1.1 and 1.D operating parameters for the 1st group and the 2.P, 2.1 and 2.D operating parameters for the 2nd group).
- Splitting the control range into three zones
 - To split the control range into three zones, define reference points 1 and 2 (i.e., the 1.RP1 and 2.RP1 setup parameters).
 - Define the 1st, 2nd and 3rd groups of PID constants (i.e., the 1.P, 1.1 and 1.D operating parameters for the 1st group, the 2.P, 2.1 and 2.D operating parameters for the 2nd group and the 3.P, 3.1 and 3.D operating parameters for the 3rd group).

Selecting PID Constants According to the Deviation

PID constants can be selected according to the deviation in two ways. One method is to select a group of PID constants only by a deviation from a program setpoint. The other method is to use a reference point, as discussed earlier, as well as a deviation from a program setpoint, to switch between groups of PID constants.

Method 1:

As shown in the figure on the right, the controller selects the PID constants of the group number set in PID group number (GRP) if the PV input value goes beyond the given deviation from the program setpoint.

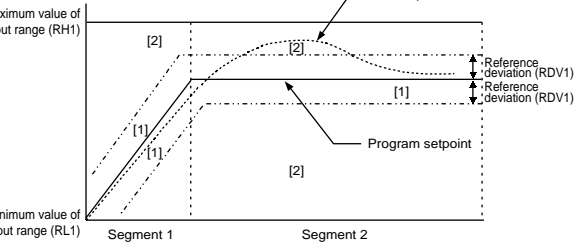

- The controller uses the 1st group of PID constants.
- The controller uses the PID constants of the group number set in PID group number (GRP).

Method 2:

As shown in the figure on the right, the controller selects an appropriate group of PID constants for each zone and, if the PV input value goes beyond the given deviation from the program setpoint, selects the PID constants of the group number set in PID group number (GRP).

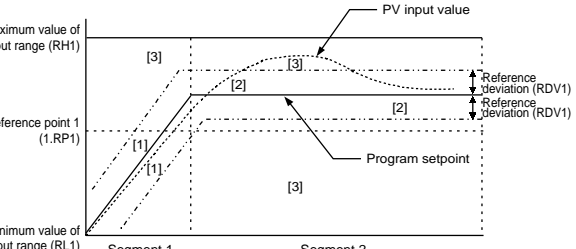

- The controller uses the 1st group of PID constants if the PV input value is both within the zone set off by the minimum value of the PV input range and reference point 1 and within the given reference deviation bandwidth.
- The controller uses the 2nd group of PID constants if the PV input value is both within the zone set off by reference points 1 and the maximum value of the PV input range, and within the given reference deviation bandwidth.
- The controller uses the PID constants of the group number set in PID group number (GRP).

Retaining the End-of-Program State (Hold-mode End)

This function keeps the controller in the same state as when program operation was completed. When in hold operation, the controller retains its states of control output and event output. To cancel hold operation, use either key operation or external contact input. When the hold operation is cancelled, the control output is set to 0% or OFF, and the event output is set to OFF.

To retain the end-of-program state, set the Junction Code program parameter of the segment in question to "1".

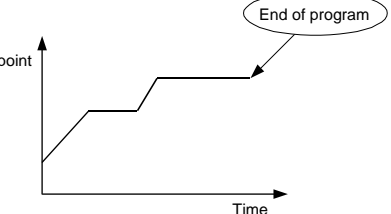

Suspending the Progress of a Program (Wait Function)

When a running program moves from one segment to another, the wait function places the program in a wait (stand-by) state, by using a wait zone and a wait time, until any deviation is cancelled. A wait zone is a deviation bandwidth from which the degree of PV input tracking is judged. A wait time is the length of time that elapses until the PV input enters the wait zone. The program progresses if the PV input fails to re-enter the wait zone within the wait time.

When the program is in wait state, the time setpoints of Segment Time and Time Event parameters temporarily cease to be passed. At this point, the output based on the Time Event parameter is retained.

See User's Manual (Reference) (CD-ROM version) for more information.

This manual describes key entries for operating the controller. For operations using external contact inputs, see "6. Terminal Wiring Diagrams" in **Installation User's Manual**. If you cannot remember how to carry out an operation during setting, press the **[DISP]** key no more than four times. This brings you to the display (operating display) that appears at power-on.

Contents

- Monitoring-purpose Operating Displays Available during Operation
- Performing/Canceling Auto-tuning
- Setting PID Manually
- Selecting Program Pattern Number (PT.No)
- Switching between RUN and RESET Modes
- Switching between AUTO and MAN
- Manipulating Control Output during Manual Operation
- Enabling/Disabling Hold Mode of Program Operation
- Changing Program Setpoints when in Hold Mode
- Executing "Advance" Function
- Switching to Local-mode (LOCAL) Operation
- Changing Setpoints during Local-mode Operation
- Troubleshooting

For description of Operation Mode, see the back of **Programming User's Manual**.

1. Monitoring-purpose Operating Displays Available during Operation

The monitoring-purpose operating displays available during operation include those for controllers of single-loop and single-loop position proportional control and those for controllers of single-loop heating/cooling control. The Process Variable (PV) display always displays the value of PV input.

Operating Displays for Single-loop and Position Proportional Single-loop Control

- SP Display**
On the Setpoint display (LCD), the controller displays the current setpoint (SP), the program pattern number (PTNO) selected, the segment number (SEGNO) for which operation is in progress, the number of segments included in the selected program pattern, the remaining time of the segment for which operation is in progress, the current number of repetitions (RCY), and the total sum of repetitions.
- Target SP Display**
On the Setpoint display (LCD), the controller displays the current setpoint (SP) and final target setpoint (TSP), the program pattern number (PTNO) selected, the segment number (SEGNO) for which operation is in progress, the number of segments included in the selected program pattern, the program pattern name (only displayed when setting the program pattern name using an optional parameter setting tool (model: LL100-E10)).
- OUT Display**
On the Setpoint display (LCD), the controller displays the current setpoint (SP), the PID number (PID) being used, the program pattern number (PTNO), the segment number (SEGNO) for which operation is in progress, the number of segments included in the selected program pattern, and the control output value (OUT), however, the value opening (0 to 100%) in position proportional control.
- Deviation Trend Display**
On the Setpoint display (LCD), the controller displays the deviation trend.
- Pattern Display**
On the Setpoint display (LCD), the controller displays the selected program pattern.
- Event Display**
On the Setpoint display (LCD), the controller displays the event number for which an event has occurred.

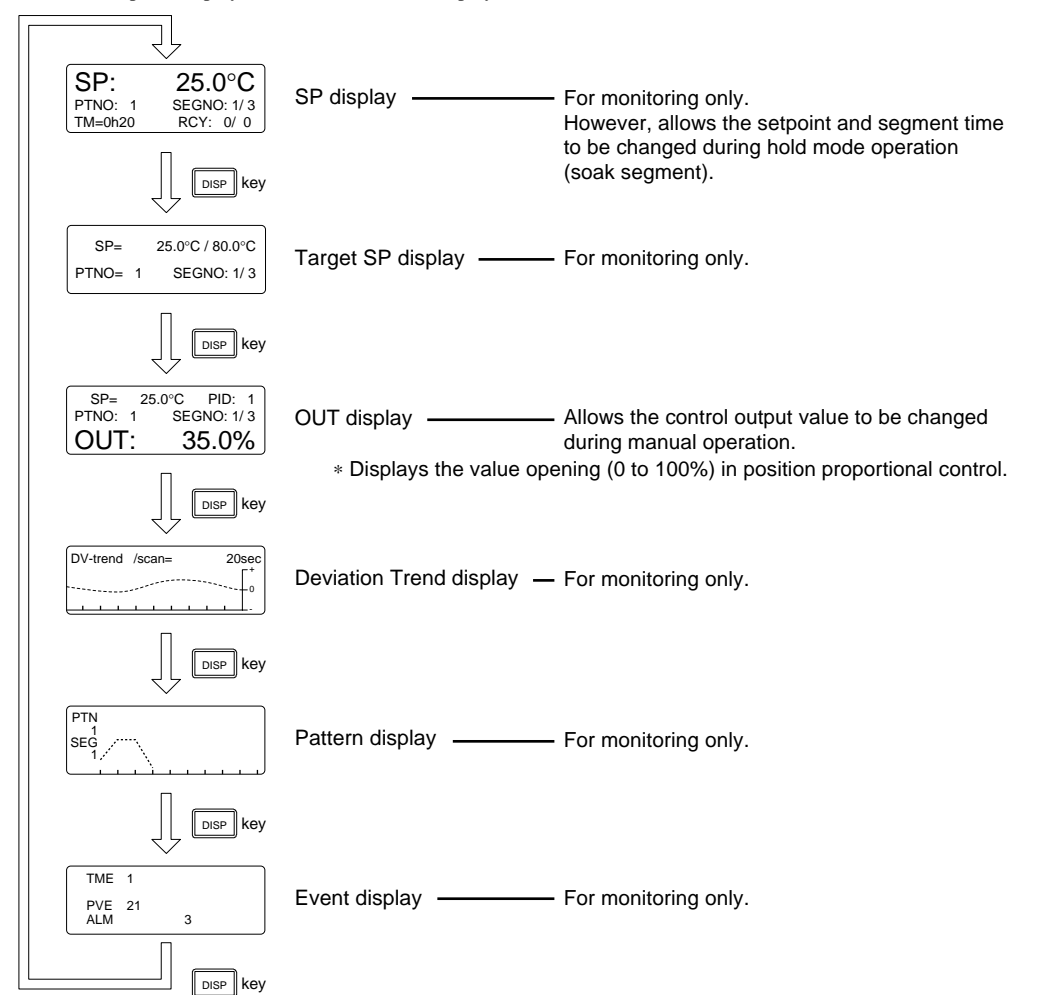

Operating Displays for Single-loop Heating/Cooling Control

- SP Display**
On the Setpoint display (LCD), the controller displays the current setpoint (SP), the program pattern number (PTNO) selected, the segment number (SEGNO) for which operation is in progress, the number of segments included in the selected program pattern, the remaining time of the segment for which operation is in progress, the current number of repetitions (RCY), and the total sum of repetitions.
- Target SP Display**
On the Setpoint display (LCD), the controller displays the current setpoint (SP) and final target setpoint (TSP), the program pattern number (PTNO) selected, the segment number (SEGNO) for which operation is in progress, the number of segments included in the selected program pattern, the program pattern name (only displayed when setting the program pattern name using an optional parameter setting tool (model: LL100-E10)).

- Heating/Cooling OUT Display**
On the Setpoint display (LCD), the controller displays the current setpoint (SP), the PID number (PID) being used, and the heating-side (HEAT) and cooling-side (COOL) control output values.
- Deviation Trend Display**
On the Setpoint display (LCD), the controller displays the deviation trend.
- Pattern Display**
On the Setpoint display (LCD), the controller displays the selected program pattern.
- Event Display**
On the Setpoint display (LCD), the controller displays the event number for which an event has occurred.

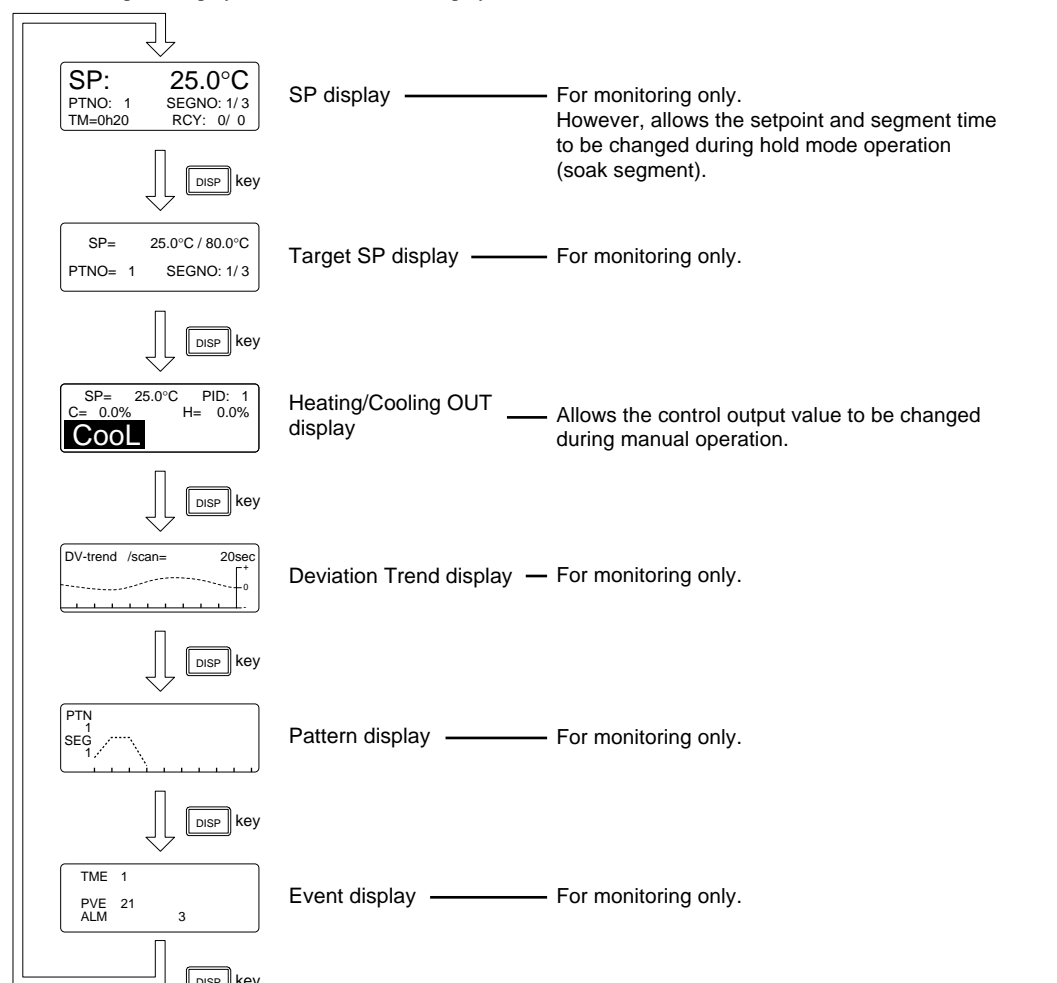

2. Performing/Canceling Auto-tuning

Perform auto-tuning when you have finished creating program patterns. Make sure the controller is in program (RUN) mode and in automatic (AUTO) mode before carrying out auto-tuning. See "5. Switching between RUN and RESET Modes" to change to RUN or "6. Switching between AUTO and MAN" to change to AUTO. PID constants are obtained by using the current program setpoint value at the start of auto-tuning. See the back of **Programming User's Manual** for more information.

NOTE

- When on-off control is being used, auto-tuning cannot be carried out. Moreover, do not perform auto-tuning when controlling any of the following processes.
- Control processes with quick response such as flow control or pressure control
 - Processes where even temporary output on/off results in inconvenience
 - Processes where a large output change at control element results in inconvenience
 - Processes where variations in PV may exceed an allowable range, adversely affecting product quality

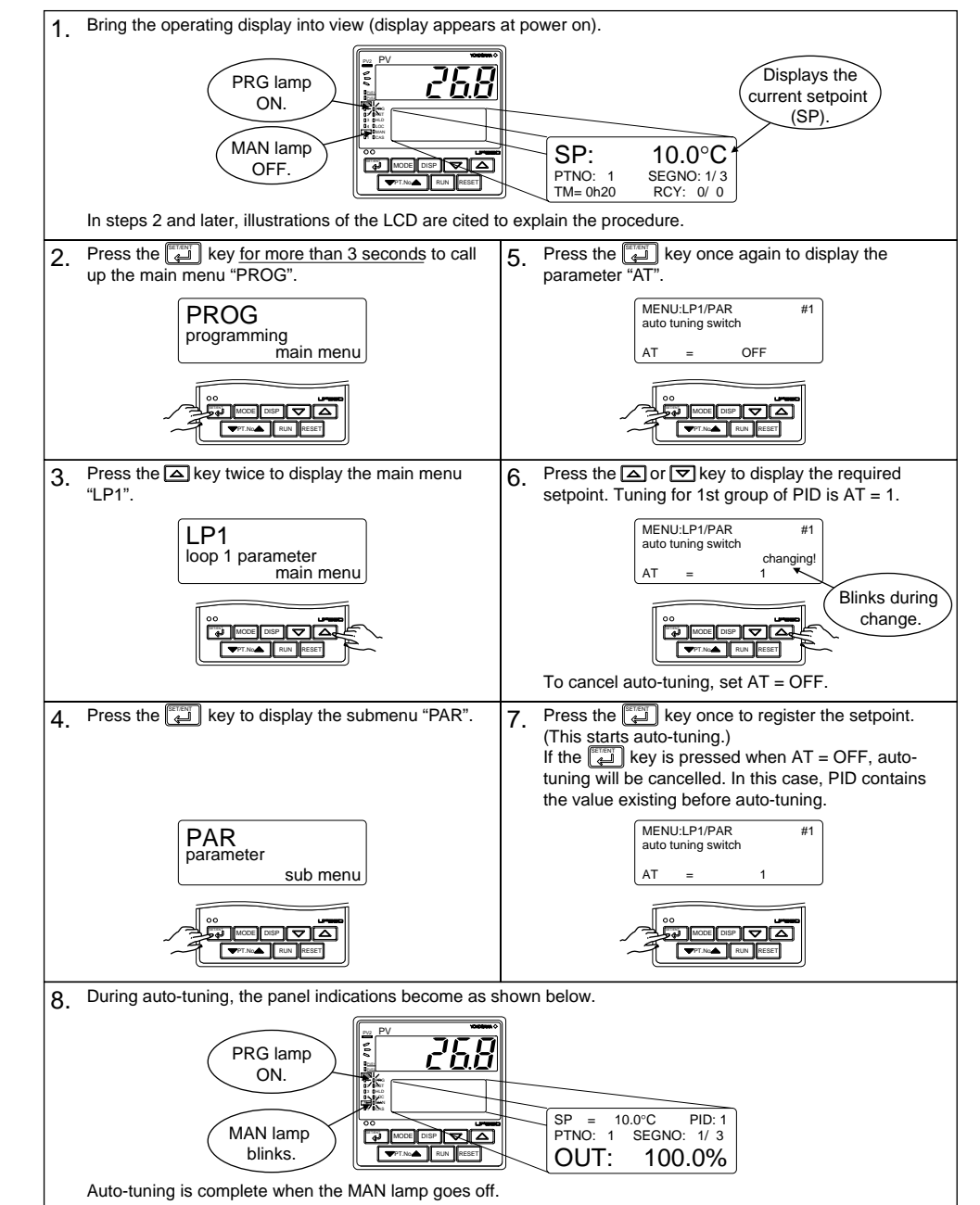

3. Setting PID Manually

If you know the values to be set or if suitable PID constants cannot be obtained by auto-tuning, follow the procedure below to set values.

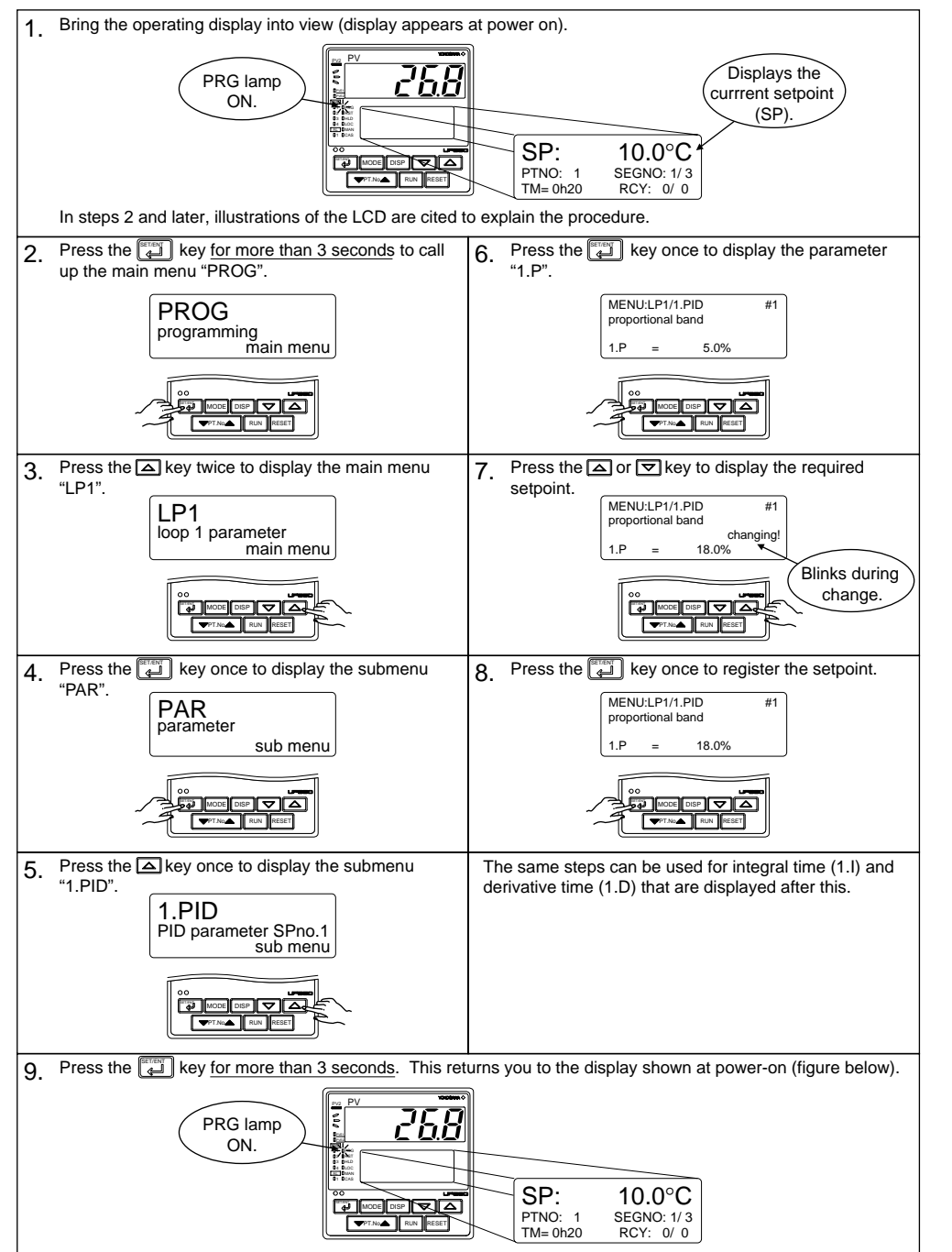

4. Selecting Program Pattern Number (PT.No)

The following operating procedure selects program pattern 1. A program pattern number can only be selected when the controller is in a RESET mode.

NOTE

If contact input, which is used to select between program pattern numbers is on, any program pattern number cannot be selected by key operation.

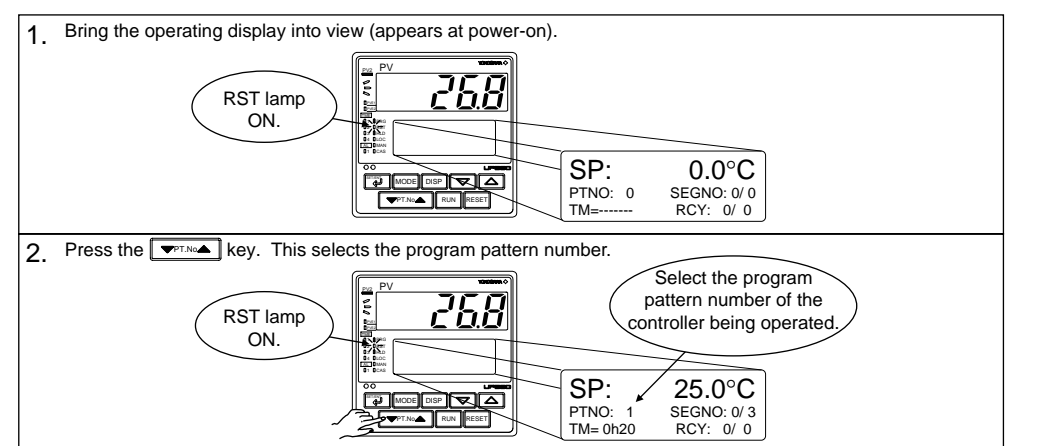

5. Switching between RUN and RESET Modes

The following operating procedure switches the RUN mode and the RESET mode.

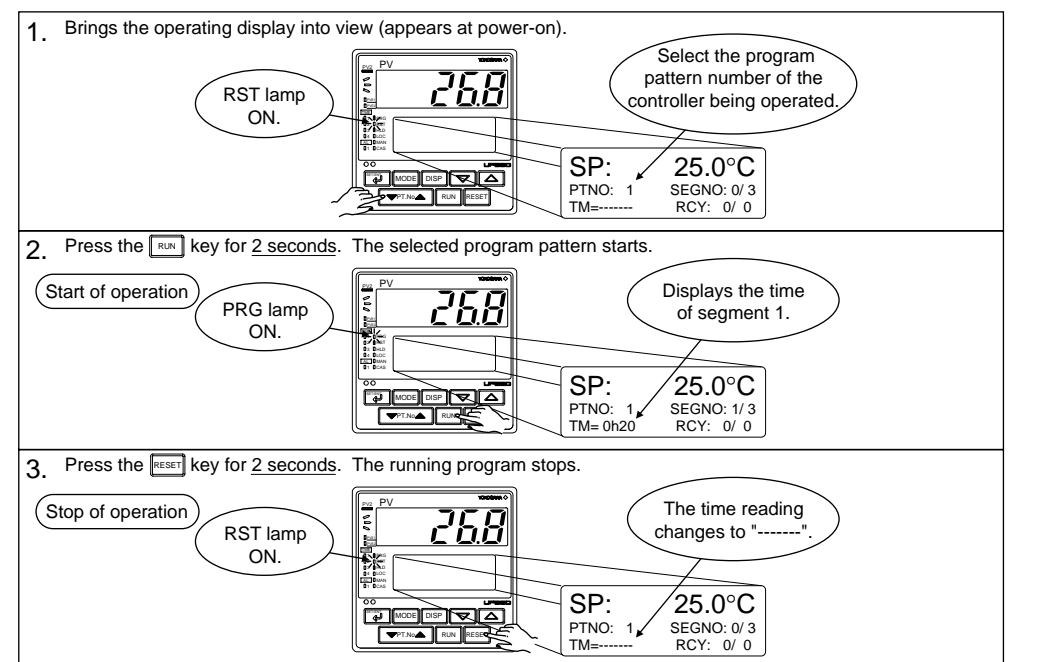

When in the RESET mode, the controller provides the following input/output values.

PV input	Value of process variable
Control output	Preset output value (factory-set to 0%)
Event output	OFF, if there is any event.

6. Switching between AUTO and MAN

NOTE

If AUTO and MAN have been switched using contact input, when the contact input is ON, switching between AUTO and MAN cannot be achieved by keystroke.

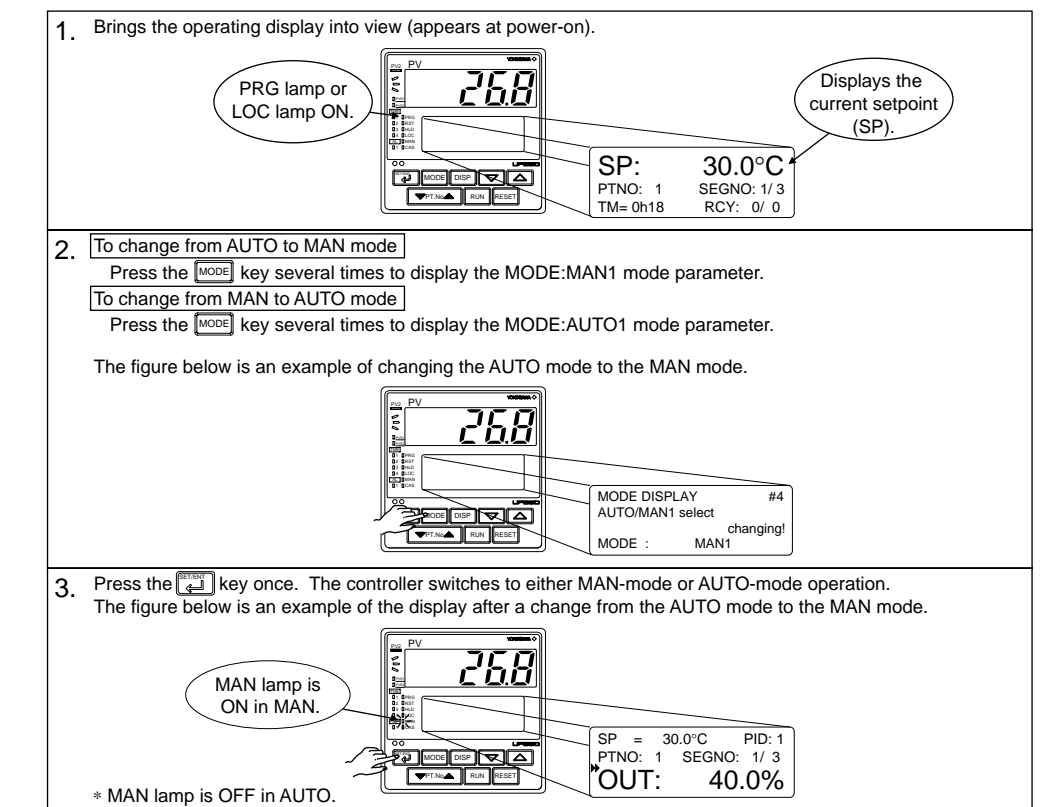

7. Manipulating Control Output during Manual Operation

NOTE

Control output cannot be changed if the controller is in the RESET mode. In this case, the preset output value (operating parameter PO) will be output.

A control output value is linked with a display value changed using the **[V]** or **[D]** key. Note that the control output changes as displayed without requiring the **[DISP]** key.

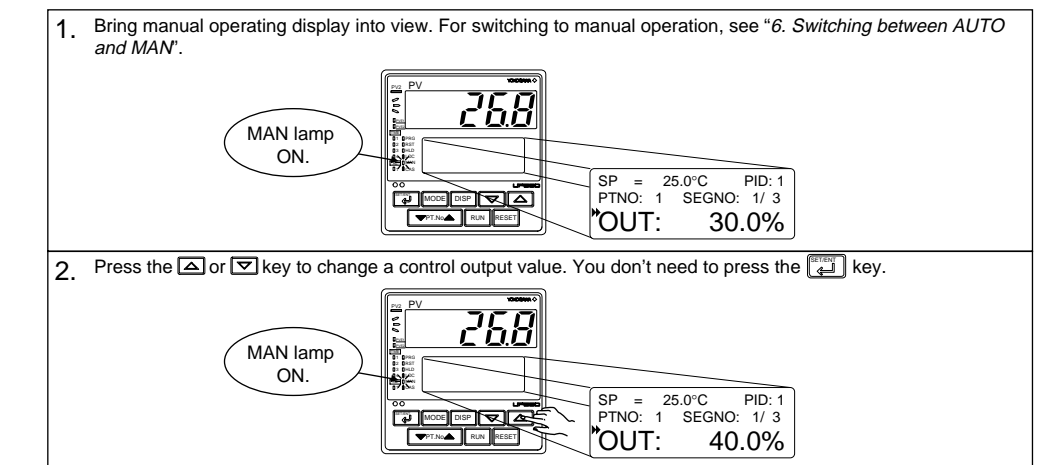

Manipulating Control Output during Heating/Cooling Control

Showing the Heating/Cooling OUT display.

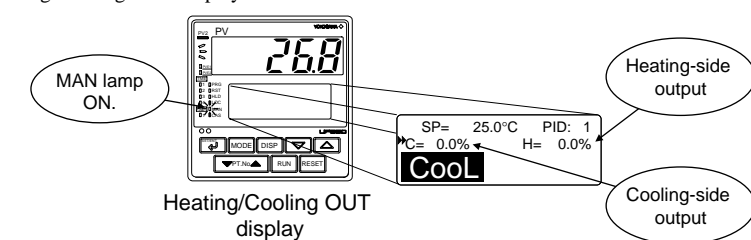

Controller behavior and control output manipulation when the dead band is positive

The following is an example when the DB parameter is set at 12.4%. If you hold down the **[V]** key with the heating-side output under manipulation (i.e., cooling-side output C = 0.0%), the heating-side output (H =) decreases. Consequently, both the heating-side and cooling-side outputs change to 0.0%. If you keep the **[V]** key held down longer, you enter the state of manipulating the cooling-side output, and its value begins to increase. Inversely, if you hold down the **[D]** key with the cooling-side output under manipulation (i.e., heating-side output H = 0.0%), the cooling-side output (C =) decreases. Consequently, both the heating-side and cooling-side outputs go to 0.0%. If you keep the **[D]** key held down longer, you enter the state of manipulating the heating-side output, and its value begins to increase.

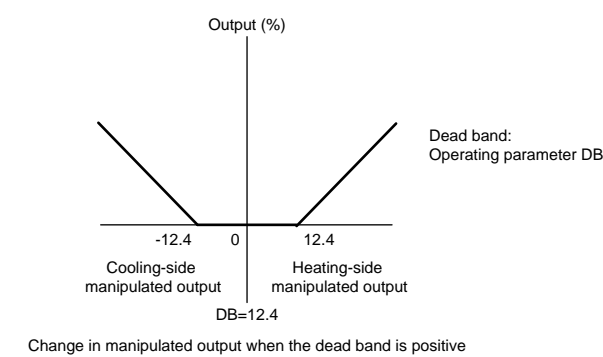

Controller behavior and control output manipulation when the dead band is negative
 The following is an example when the DB parameter is set at -12.4%.
 If you hold down the key with the heating-side output under manipulation (i.e., cooling-side output C = 0.0%), the heating-side output (H =) decreases. If the output H falls below 24.8%, the cooling-side output C begins to increase from 0.0%. If you keep the key held down longer and the output C rises above 24.8%, the output H goes to 0.0% and you enter the state of manipulating the cooling-side output.

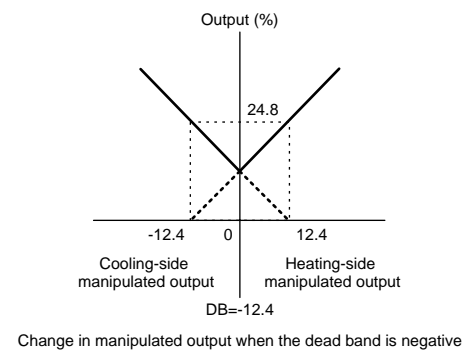

Manipulating the Control Output during Position Proportional Control
 The controller continues to provide control output as long as the or key is being pressed.
 key: Closes the valve.
 key: Opens the valve.

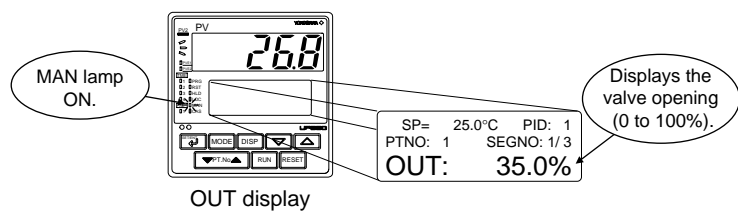

Note: Manual output is not limited to output high limit(OH) and output low limit(OL).

8. Enabling/Disabling Hold Mode of Program Operation

Enabling/disabling the hold mode of program operation should be done when the controller is in operation. The following operating procedure is an example of setting program operation in the hold mode.

- Bring the operating display into view (appears at power-on).
- To enable the hold mode of program operation, press the key once to display the HOLD:ON mode parameter. To disable the hold mode of program operation, press the key once to display the HOLD:OFF mode parameter. The figure below is an example of enabling the hold mode of program operation.
- Press the key once. The controller switches to either hold mode or non-hold mode.

* Other operating procedures for disabling the hold mode:
 [1] Press the key for two seconds during hold-mode operation. In this case, the controller resumes program operation.
 [2] Execute the "advance" function during hold-mode operation. In this case, the segment is advanced.

9. Changing Program Setpoints when in Hold Mode

The following operating procedure changes program setpoints when program operation (in soak segment) is put in the hold mode. When you have finished changing the setpoints, disable the hold mode of program operation as instructed in "8. Enabling/Disabling Hold Mode of Program Operation." The controller resumes program operation when the hold mode is disabled.

- Set program operation in the hold mode. To do this, see "8. Enabling/Disabling Hold Mode of Program Operation."
- Press the key once to display the symbol "▶▶".
- Press the or key to change the setpoint.
- Press the key once to register the setpoint.

How to Change the Target Setpoint in the Segment being in Operation

- Set the program operation in the hold mode.
- Change the target setpoint of the corresponding segment of operation program on the program parameter setting display.
- When the hold mode of program operation is disabled, the controller resumes the control toward the changed target setpoint.

Note: To perform the above, specify "programming by setting segment times" for segment setting method (SEG.T setup parameter), and do not change the hold SP and hold time on the operating display in HOLD mode.

10. Executing "Advance" Function

The following operating procedure advances the controller from segment 1 to segment 2. If you execute the "advance" function during hold-mode operation, the hold mode is disabled.

- Bring the current operating display for program operation into view.
- Press the key twice to display the ADV:ON mode parameter.
- Press the key once. The controller resumes operation from the target setpoint of segment 1.

11. Switching to Local-mode (LOCAL) Operation

The controller can be switched to local-mode operation when it is in program operation or in a RESET mode. The following operating procedure switches the controller to local-mode operation during program operation.

- Bring the current display for program operation into view.
- Press the key several times to display the LOC:ON mode parameter.
- Press the key once. The controller begins running with a local setpoint (L.SP).

12. Changing Setpoints during Local-mode Operation

The following operating procedure changes setpoints during local-mode operation.

- Change the controller to local-mode operation. To do this, see "11. Switching to Local-mode (LOCAL) Operation."
- Press the or key to change the local setpoint.
- Press the key once to register the setpoint.

13. Troubleshooting

Troubleshooting Flow

If the operating display does not appear after turning on the controller's power, follow the measures in the procedure below. If a problem appears complicated, contact our sales representative.

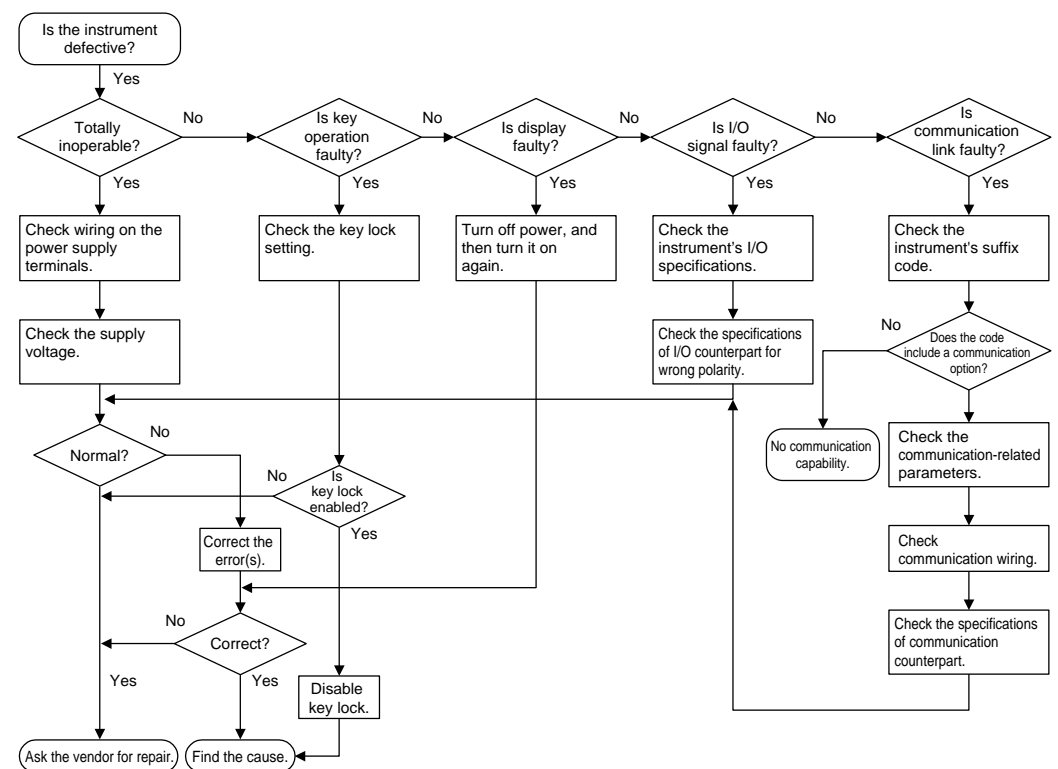

IMPORTANT

Take note of the parameter settings when asking the vendor for repair.

Errors at Power On

The following table shows errors that may be detected by the fault diagnosis function when the power is turned on.

Display position (Note)	Error indication	Description of error	PV	Control output	Alarm output	Retransmission output	Communication	Remedy
1	E000	Faulty RAM	None	0% or less or OFF	OFF	0% or less	Stopped	Faulty Contact us for repair.
	E001	Faulty ROM	None	0% or less or OFF	OFF	0% or less	Stopped	
	E002	System data error	Undefined	Undefined	Undefined	Undefined	Stopped	
	PV decimal point blinks.	Faulty calibration value	Normal action (out of accuracy)	Normal action (out of accuracy)	Normal action (out of accuracy)	Normal action (out of accuracy)	Normal action	Check and set the initialized parameters.
2	Error code (See description below)	Parameter error	Normal action	0% or less or OFF	Normal action	Normal action	Normal action	Check and set the initialized parameters.

Note: 1: PV display 2: Setpoint display
 An error code is displayed in the event of an error, according to its type. An error code is a two-digit figure in which a combination of 6 bits of on and off is converted into a decimal number. The following shows the relationship between each bit and parameter to be checked for abnormality.

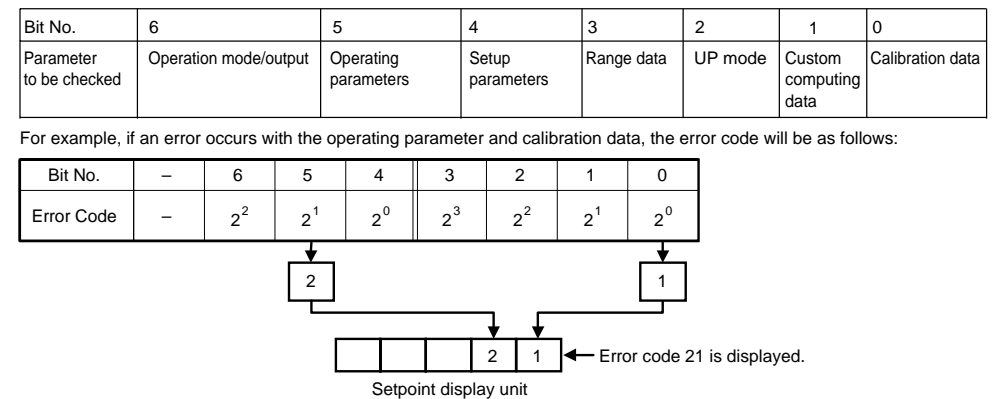

Possible Errors during Operation

The following shows possible errors occurring during operations.

Display position (Note)	Error indication	Description of error	PV	Control output	Alarm output	Retransmission output	Communication	Remedy
3	Displays "RJC" and PV alternately	RJC error	Measured with RJC=OFF	Normal action				Faulty Contact us for repair.
	E300	ADC error	105%	In AUTO: Preset value output In MAN: Normal action		Normal action		
	B.OUT	PV burnout error	Dependent on the BSL parameter Up-scale: 105% Down-scale: -5%					
3	OVER or -OVER	Excessive PV Out of -5 to 105%	-5% or 105%	Normal action	Normal action		Normal action	Check process.
	E200	Auto-tuning failure (Time-out)		Action with PID existing before auto-tuning		Normal action		Check process. Press any key to erase error indication.
2		Feedback resistor burnout	Normal action	Stopped		Stopped		Check the feedback resistor.
	Blinking dot in the most left on LCD.	Faulty communication line		Normal action		Normal action		Check wires and communication parameters, and make resetting. Recovery at normal receipt
1	Decimal point at right end lights.	Runaway (due to defective power or noise)	Undefined	0% or less or OFF	OFF	0% or less	Stopped	Faulty if power off/on does not reset start the unit. Contact us for repair.
No display	All indications off	Power off	None					Check for abnormal power.

Note: 1: PV display, 2: LCD, 3: Display showing the PV of the loop in which the error has been caused.

Remedies if Power Failure Occurs during Operations

The operation status and remedies after a power failure differ with the length of power failure time:

- Instantaneous power failure of 20 ms or less
 - A power failure is not detected. Normal operation continues.
- Power failure of about 2 seconds or less
 - The following show effects caused in "settings" and "operation status."

Alarm action	Continues. Alarm with standby function will enter standby status.
Setting parameter	Set contents of each parameter are retained.
Auto-tuning	Cancelled.
Control action	Action before power failure continues.

- Power failure of more than about 2 seconds
 - The following show effects caused in "settings" and "operation status."

Alarm action	Continues. Alarm with standby function will enter standby status.								
Setting parameter	Set contents of each parameter are retained.								
Auto-tuning	Cancelled.								
Control action	Differs with setting of setup parameter "R.MD"(restart mode). <table border="1"> <thead> <tr> <th>R.MD setting</th> <th>Control action after recovery from power failure</th> </tr> </thead> <tbody> <tr> <td>CONT</td> <td>Continues action before power failure. (Factory-set default) For position-proportional type, when V.MOD = Valve position estimating type, starts action from 0%.</td> </tr> <tr> <td>MAN</td> <td>Outputs preset output value (PO) as control output and continues action set before power failure in MAN mode. For position-proportional type, when V.MD = Valve position feedback type, starts action from feedback input condition at recovery from power failure. When V.MD = Valve position estimating type, starts action from 0%. For heating/cooling control, starts action from heating-side output value and cooling-side output value of 50% of control computation output.</td> </tr> <tr> <td>RESET</td> <td>Outputs preset output value (PO) as control output and continues action set before power failure in AUTO mode. For position-proportional type, when V.MD = Valve position feedback type, starts action from feedback input condition at recovery from power failure. When V.MD = Valve position estimating type, starts action from 0%. For heating/cooling control, starts action from heating-side output value and cooling-side output value of 50% of control computation output.</td> </tr> </tbody> </table>	R.MD setting	Control action after recovery from power failure	CONT	Continues action before power failure. (Factory-set default) For position-proportional type, when V.MOD = Valve position estimating type, starts action from 0%.	MAN	Outputs preset output value (PO) as control output and continues action set before power failure in MAN mode. For position-proportional type, when V.MD = Valve position feedback type, starts action from feedback input condition at recovery from power failure. When V.MD = Valve position estimating type, starts action from 0%. For heating/cooling control, starts action from heating-side output value and cooling-side output value of 50% of control computation output.	RESET	Outputs preset output value (PO) as control output and continues action set before power failure in AUTO mode. For position-proportional type, when V.MD = Valve position feedback type, starts action from feedback input condition at recovery from power failure. When V.MD = Valve position estimating type, starts action from 0%. For heating/cooling control, starts action from heating-side output value and cooling-side output value of 50% of control computation output.
R.MD setting	Control action after recovery from power failure								
CONT	Continues action before power failure. (Factory-set default) For position-proportional type, when V.MOD = Valve position estimating type, starts action from 0%.								
MAN	Outputs preset output value (PO) as control output and continues action set before power failure in MAN mode. For position-proportional type, when V.MD = Valve position feedback type, starts action from feedback input condition at recovery from power failure. When V.MD = Valve position estimating type, starts action from 0%. For heating/cooling control, starts action from heating-side output value and cooling-side output value of 50% of control computation output.								
RESET	Outputs preset output value (PO) as control output and continues action set before power failure in AUTO mode. For position-proportional type, when V.MD = Valve position feedback type, starts action from feedback input condition at recovery from power failure. When V.MD = Valve position estimating type, starts action from 0%. For heating/cooling control, starts action from heating-side output value and cooling-side output value of 50% of control computation output.								

Troubleshooting When the Controller Fails to Operate Correctly

If your control tasks are not successful, check the preset parameters and controller wiring before concluding the controller to be defective. The following show some examples of troubleshooting you should refer to in order to avoid the possibility of other problems.

The controller does not show the correct measured input (PV).

- The UP550 controllers have a universal input. The type of PV input can be set/changed using the parameter "IN1". At this point, the controller must be wired correctly according to the selected type of PV input. Check the wiring first if the controller fails to show the correct PV value. To do this, refer to "Initial Settings User's Manual". With the parameters "RH1", "RL1", "SDP1", "SH1" and "SL1", it is possible to scale the input signal and change its number of decimal places. Also check that these parameters are configured correctly.

The controller does not provide any control output or the control output does not change at all.

- The UP550 controllers have a universal output. The type of control output can be set/changed using the parameter "OT1". At this point, the controller must be wired correctly according to the selected type of control output. Check the wiring first if the controller provides no control output. To do this, refer to "6. Terminal Wiring Diagrams," in "Installation User's Manual". With the parameters "OH" and "OL", it is possible to set/change the high and low limits of control output. The control output may not change at all, however, because of restrictions on these parameters. Also check the restrictions on these parameters.
- The control output can only be changed when the controller is in the MAN mode. If the MAN lamp is off (i.e., the controller is in the AUTO mode), you cannot change the control output using key operation.

The control output does not change soon after the target setpoint (SP) has been changed.

- If this happens, check the setpoint of the parameter "MOD1". In cases where fixed-point control is selected as the PID control mode (MOD1 = 1), tracking based on the I-term works to prevent the control output from changing suddenly even if the target setpoint (SP) is varied. The control output therefore may appear to be working incorrectly at first; however it gradually adapts itself to the new target setpoint.



This manual contains a parameter map as a guideline for setting parameters.

If you are unsure of the key operation sequence, press the **DISP** key no more than four times. This displays a screen at power on (i.e., operating display).

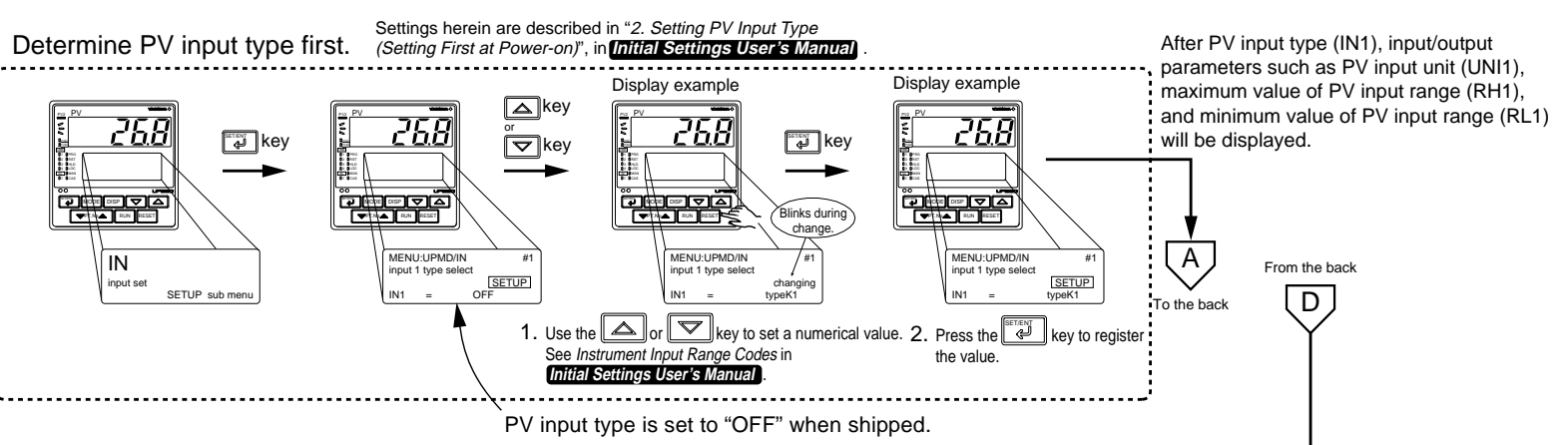

- Basic Key Operation Sequence**
- Setting display can be switched (moved) using the **DISP** key.
 - A numerical value is changed by:
 - Using the **▲** or **▼** key to change a displayed value ("changing" blinking) and
 - Pressing the **▶** key to register it.
 - Pressing the **DISP** key on an operating display (for more than 3 seconds) brings you to the operating parameter setting display.
 - Pressing the **DISP** key on the operating parameter setting display (for more than 3 seconds) returns you to the operating display. To change from the operating parameter setting display to the operating parameter menu display, press the **▶** key.
 - Pressing the **DISP** key on the setup parameter setting display (for more than 3 seconds) returns you to the setup parameter display. To change from the setup parameter setting display to the setup parameter menu display, press the **▶** key.

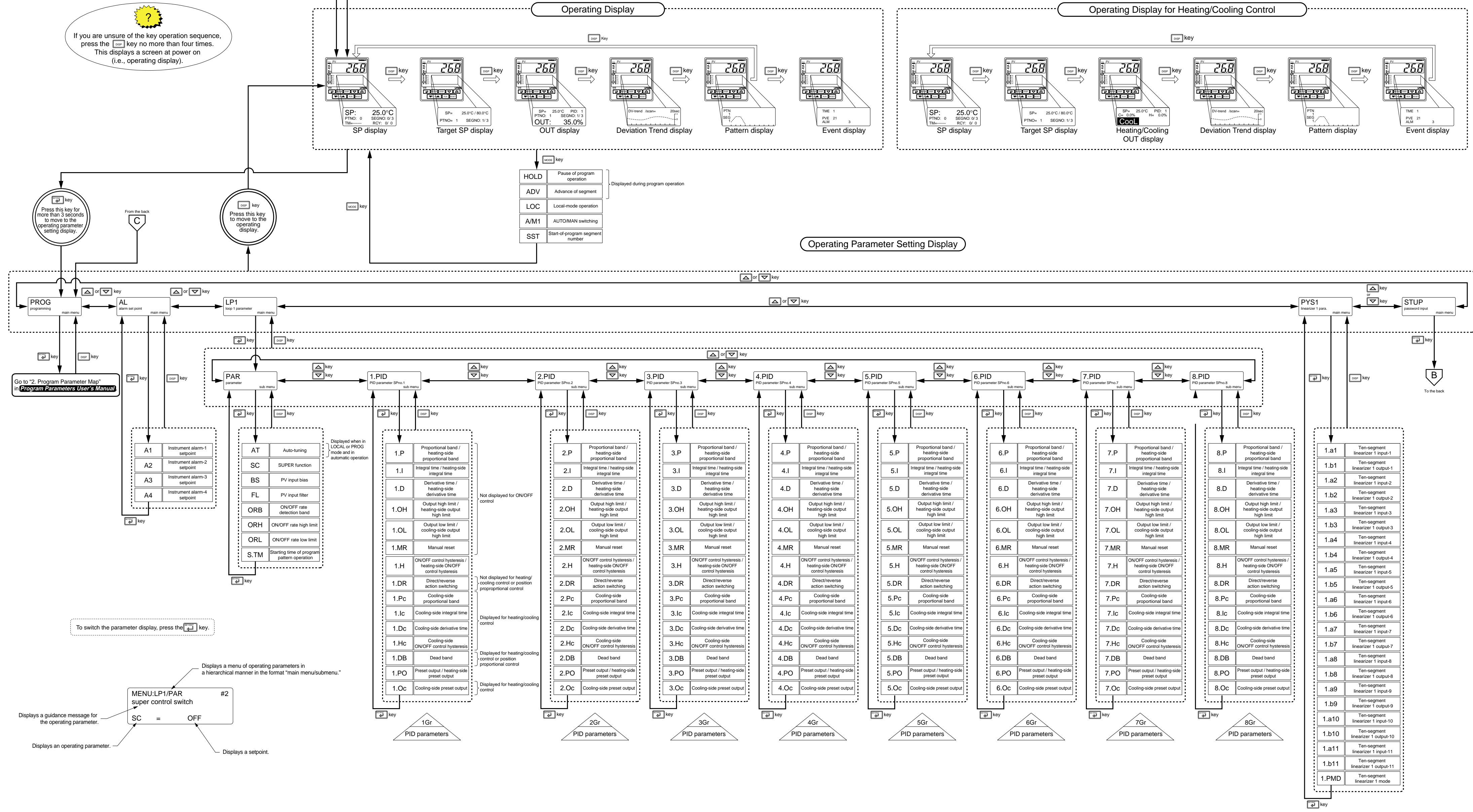

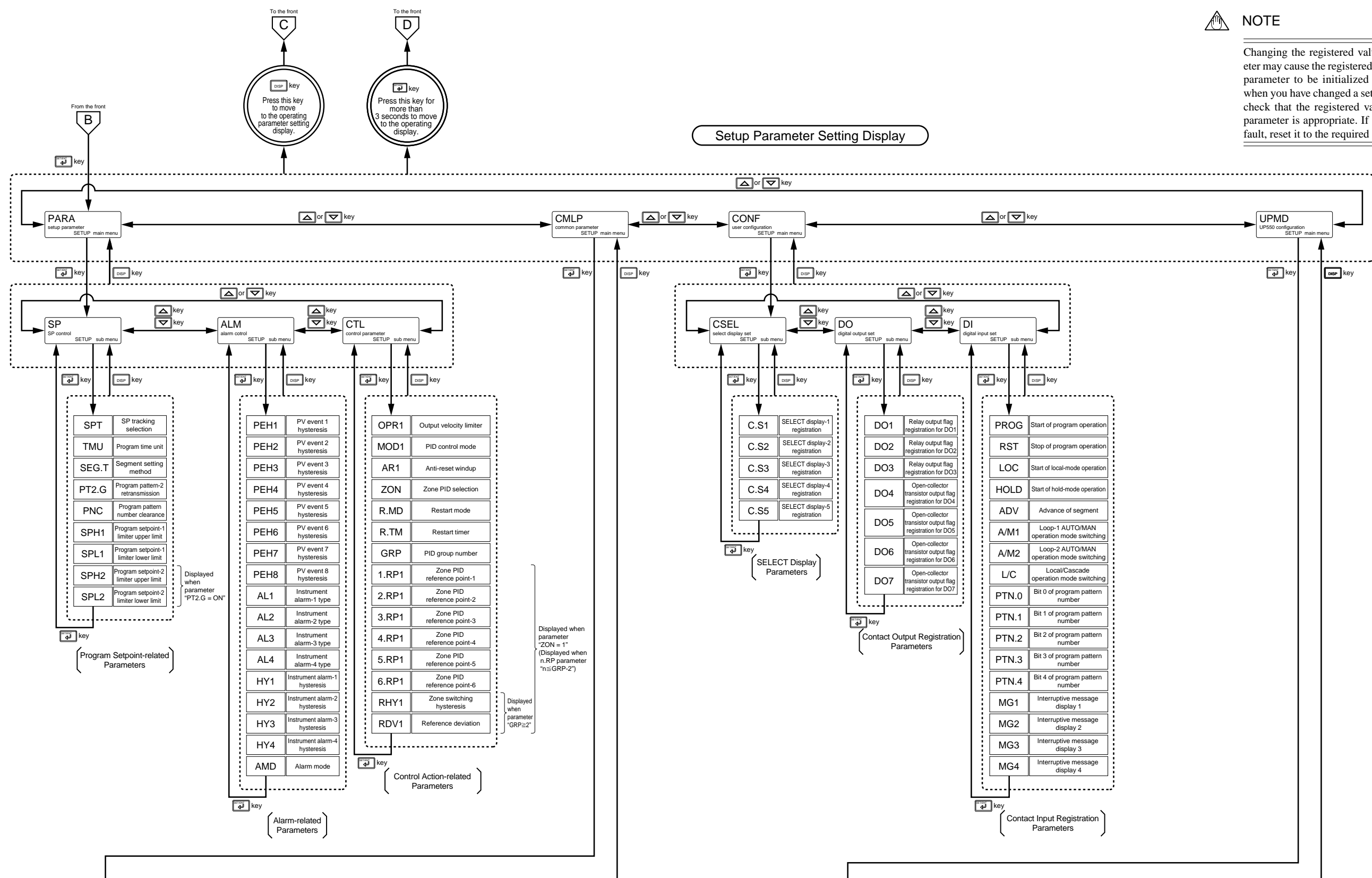

NOTE

Changing the registered value of a setup parameter may cause the registered value of an operating parameter to be initialized automatically. Thus, when you have changed a setup parameter, always check that the registered value of the operating parameter is appropriate. If it is initialized to default, reset it to the required value.

List of PV Event Types, Local Event Types, and Instrument Alarm Types

The table below shows the types and actions of PV event, Local event and Instrument alarm. In the table, codes 1 to 10 are not provided with stand-by actions, while codes 11 to 20 (available for Instrument Alarm only) are provided with stand-by actions.

Alarm type	Alarm action	Alarm type code		Alarm type	Alarm action	Alarm type code	
		Contact closes if alarm occurs	Contact opens if alarm occurs			Contact closes if alarm occurs	Contact opens if alarm occurs
No alarm			OFF				
PV high limit	Open (unit) / Closed (lit)	1	11	De-energized on deviation low limit alarm	Hysteresis		6
PV low limit	Closed (lit) / Open (unit)	2	12	Deviation high and low limits	Hysteresis		7
Deviation high limit	Open (unit) / Closed (lit)	3	13	Deviation within high and low limits	Hysteresis		8
Deviation low limit	Closed (lit) / Open (unit)	4	14	De-energized on PV high limit	Hysteresis		9
De-energized on deviation high limit alarm	Closed (unit) / Open (lit)		5	De-energized on PV low limit	Hysteresis		10
SP high limit	Open (unit) / Closed (lit)		28	Output high limit	Hysteresis		30
SP low limit	Closed (lit) / Open (unit)		29	Output low limit	Hysteresis		31

The following alarm type are used only for "Instrument Alarm."
 25: Sensor grounding alarm
 26: Fault diagnosis output (Note1)
 27: FAIL output (Note2)

Note1: The fault diagnosis output turns on in case of input burnout, A/D converter failure, or reference junction compensation (RJC) failure.
 For input burnout or A/D converter failure, the control output is set to the setpoint of the Preset Output Value operating parameter (PO).
 Note2: The FAIL output is on during normal operation and turns off in case of failure.

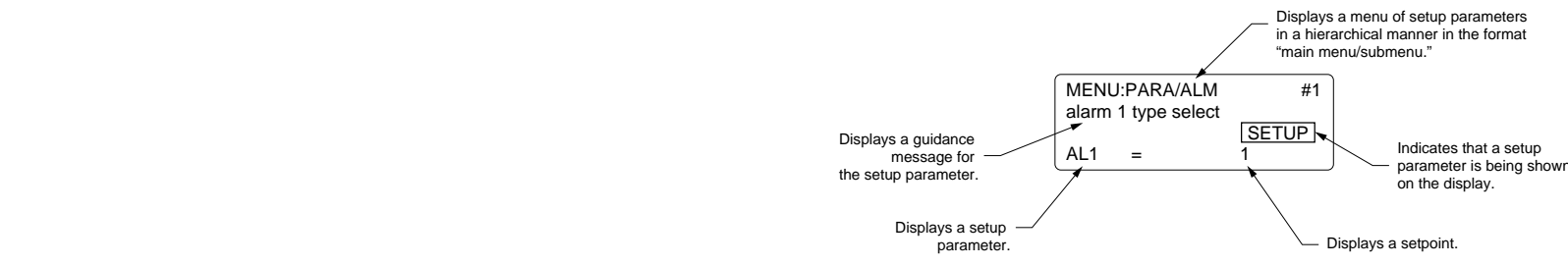
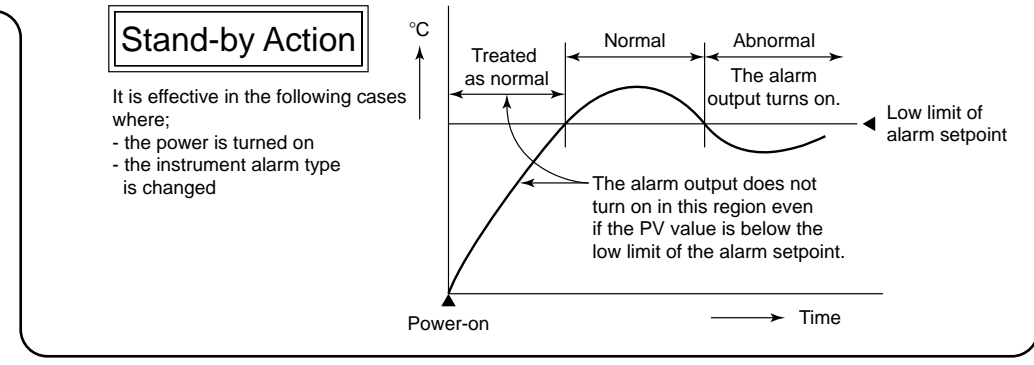
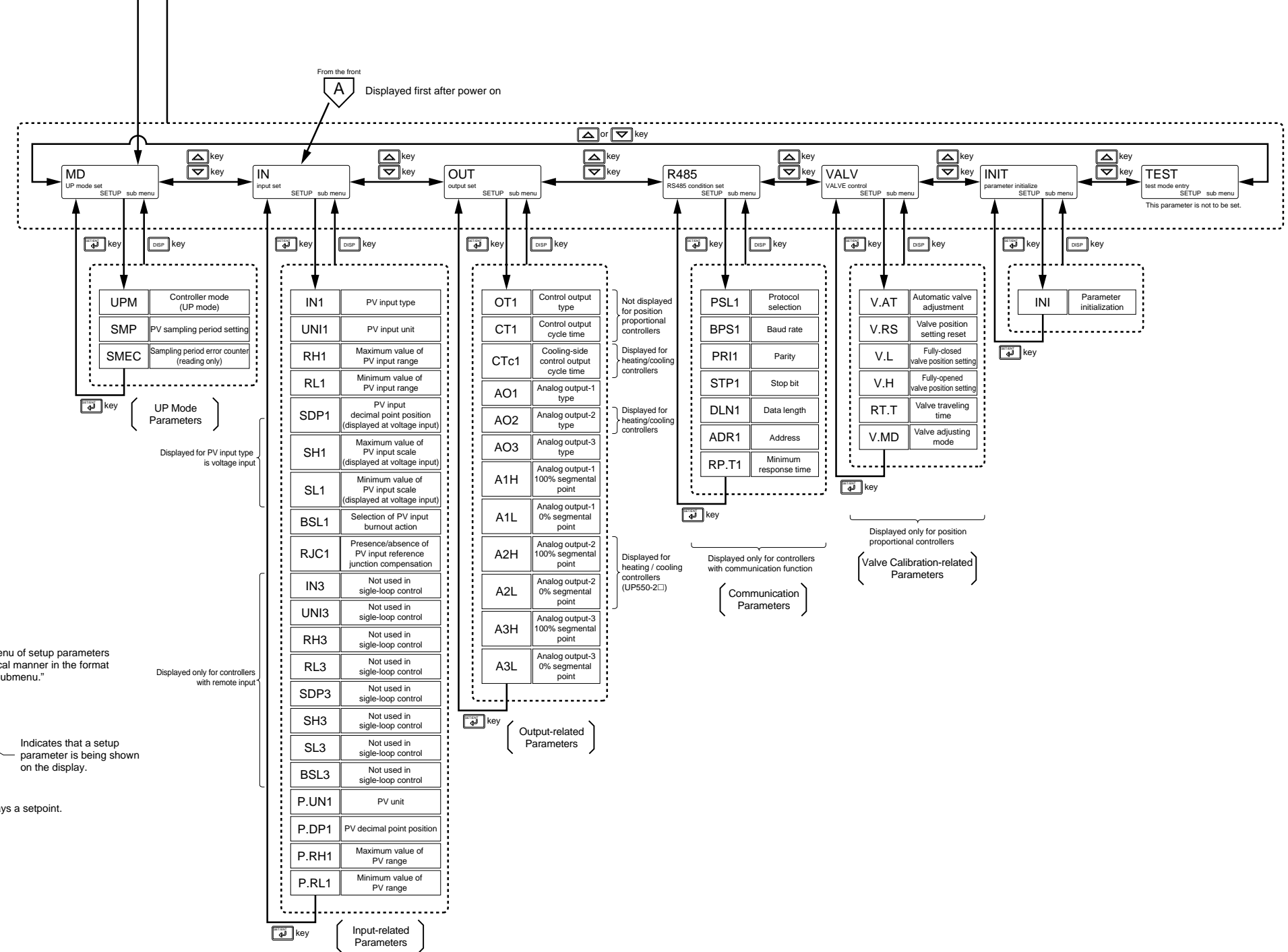
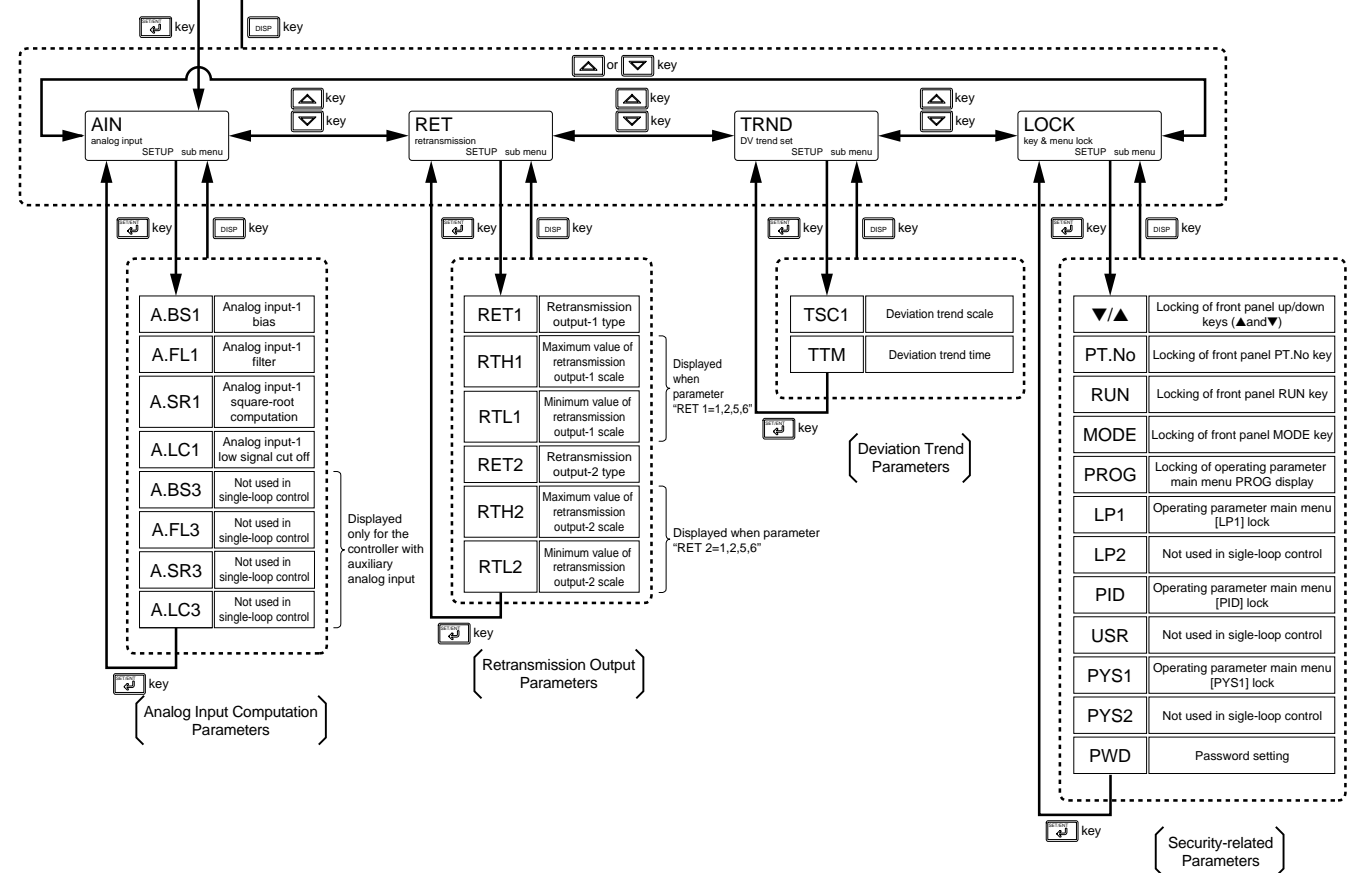

This manual describes the functions of parameters briefly. In addition, each parameter table has a "User Setting" column, where you can record your setpoints when setting them in the controller.

Operation Mode Parameters

Located in: MODE key (key on the instrument's front panel)

Parameter Symbol	Name of Parameter	Setting Range and Description	Initial Value	User Setting	Target Item in CD-ROM
HOLD	Pause of program operation	Set as "HOLD = ON" to enable the hold mode of program operation.	—	—	Ref.5.2(5)
ADV	Advance of segment	Set as "ADV = ON" to advance from the current segment to the next segment.	—	—	Ref.5.2(7)
LOC	Local-mode operation	Set as "LOC = ON" to switch from program operation or RESET mode to local-mode operation.	—	—	Ref.5.2(9)
A/M1	AUTO/MAN switching	To switch between AUTO and MAN: To switch to AUTO mode, display "MODE: AUTO1", then press the key. To switch to MAN mode, display "MODE: MAN1", then press the key.	—	—	—
SST	Start-of-program segment number	1 to 99 Program operation begins with the segment whose number is specified by this parameter.	1	—	—

Operating Parameters

Instrument Alarm Setting Parameters

Located in: Main menu = AL

Parameter Symbol	Name of Parameter	Setting Range and Description	Initial Value	User Setting	Target Item in CD-ROM
A1	Instrument alarm-1 setpoint	Allows alarm action to be set irrespective of the program.	PV high limit/SP high limit alarm: 100.0% of PV input range Deviation alarm: 0.0% of PV input range span Other PV/SP low limit alarm: 0.0% of PV input range	—	Ref.3.4(1)
A2	Instrument alarm-2 setpoint	PV alarm / SP alarm: -100.0 to 100.0% of PV input range Deviation alarm: -100.0 to 100.0% of PV input range span Output alarm: -5.0 to 105.0%	—	—	
A3	Instrument alarm-3 setpoint	—	—	—	
A4	Instrument alarm-4 setpoint	—	—	—	

Operation-related Parameters

Located in: Main menu = LP1 ; Submenu = PAR

Parameter Symbol	Name of Parameter	Setting Range and Description	Initial Value	User Setting	Target Item in CD-ROM
AT	Auto-tuning	OFF: No auto-tuning 1: Auto-tuning for 1st group of PID 2: Auto-tuning for 2nd group of PID 3: Auto-tuning for 3rd group of PID 4: Auto-tuning for 4th group of PID 5 to 8: Perform auto-tuning on a group basis in the same way as 1 to 4 9: Performs auto-tuning to all groups 1 to 8.	OFF	—	—
SC	"SUPER" function	OFF: Disable 1: Overshoot suppressing function 2: Hunting suppressing function (Stable mode) 3: Hunting suppressing function (Response mode) 4: Hunting suppressing function (Response mode) Note: Use "SUPER" function (SC) 2 or 3 in PID control or P control. "SUPER" function 2 or 3 is not available in the following control: 1) ON/OFF control 2) Control (control for proportional band only) 3) PID control (control for proportional band and derivative term only) 4) Heating/cooling control Do not use hunting suppressing function when control process with response such as flow or pressure control.	OFF	—	Ref.2.1(5) Ref.2.1(6)
BS	PV input bias	-100.0% to 100.0% of PV input range span Used to correct the PV input value.	0.0% of PV input range span	—	Ref.1.1(1)
FL	PV input filter	OFF, 1 to 120 sec Used when the PV input value fluctuates.	OFF	—	—
ORB	ON/OFF rate detection band	0.0 to 100.0% of PV input range span	1.0% of PV input range span	—	—
ORH	ON/OFF rate high limit	ORL + 1 digit to 105.0%	100.0 %	—	Ref.3.4(4)
ORL	ON/OFF rate low limit	-5.0% to ORH - 1 digit	0.0%	—	—
S.TM	Starting time of program pattern operation	0.0 to 99.59 ("hour, minute" or "minute, second") The controller begins control when the specified time has passed after power-on.	0.00	—	Ref.5.2(2)

PID-related Parameters

Located in: Main menu = LP1 ; Submenu = 1.PID

Parameter Symbol	Name of Parameter	Setting Range and Description	Initial Value	User Setting	Target Item in CD-ROM
1.P	Proportional band/Heating-side proportional band (in heating/cooling control)	0.1 to 999.9% of PV input range In heating/cooling control: 0.0 to 999.9%	5.0%	—	—
1.I	Integral time Heating-side integral time (in heating/cooling control)	OFF, 1 to 6000 sec.	240 sec.	—	—
1.D	Derivative time Heating-side derivative time (in heating/cooling control)	OFF, 1 to 6000 sec.	60 sec.	—	—
1.OH	Output high limit Heating-side output high limit (in heating/cooling control)	-5.0 to 105.0% Heating-side limiter in heating/cooling control: 0.0 to 105.0% (1.OH < 1.OH)	100% Heating/cooling control: 100.0%	—	—
1.OL	Output low limit Cooling-side output high limit (in heating/cooling control)	-5.0 to 105.0% Cooling-side limiter in heating/cooling control: 0.0 to 105.0% (1.OL < 1.OH) SD (shutdown): Set in manual operation in 4.20 mA control output. Output is 0 mA.	0.0% Heating/cooling control: 100.0%	—	Ref.2.1(3)
1.MR	Manual reset (enabled when integral time "1.I" is OFF) The manual reset value equals the output value when PV = SP is true. For example, if the manual reset value is 50%, the output value is 50% when PV = SP becomes true.	-5.0 to 105.0%	50.0%	—	—

* The "User Setting" column in the table below is provided for the customer to record setpoints.
 * The column "Target Item in CD-ROM" in the table below provides references from User's Manual (Reference) (CD-ROM Version) which describes items in more detail and items that are not contained in this manual.

Parameter Symbol	Name of Parameter	Setting Range and Description	Initial Value	User Setting	Target Item in CD-ROM
1.H	ON/OFF control hysteresis Heating-side ON/OFF control hysteresis (in heating/cooling control)	In ON/OFF control: 0.0 to 100.0% of PV input range span Position proportional PID control or heating/cooling control: 0.0 to 100.0% Hysteresis can be set in the program setpoint when the controller is performing ON/OFF control. 	0.5%	—	—
1.DR	Direct/reverse action switching	REVERSE: reverse action, DIRECT: direct action 	—	—	Ref.2.1(1)
1.Pc	Cooling-side proportional band	0.0 to 999.9% of PV input range (Cooling-side ON/OFF control applies when 0.0)	5.0%	—	—
1.Ic	Cooling-side integral time	OFF, 1 to 6000 sec.	240 sec.	—	—
1.Dc	Cooling-side derivative time	OFF, 1 to 6000 sec.	60 sec.	—	—
1.Hc	Cooling-side ON/OFF control hysteresis	0.0 to 100.0%	0.5%	—	—
1.DB	Dead band	In heating/cooling control: -100.0 to 50.0% In position proportional PID control: 1.0 to 10.0% • When performing heating/cooling control: When setting any positive value, there is a region where none of the heating- and cooling-side output is presented, when setting any negative value, there is a region where both of heating- and cooling-side outputs are presented. • When performing position proportional control: set the range so none of the outputs turn on.	3.0%	—	—
1.PO	Preset output/Heating-side preset output (in heating/cooling control)	-5.0 to 105.0% In REVERSE mode, fixed control output can be generated.	0.0%	—	Ref.2.1(8)
1.Oc	Cooling-side preset output	0.0 to 105.0% In REVERSE mode, cooling-side fixed control output can be generated.	0.0%	—	—

If you are using two or more groups of PID parameters, use the following table to record their values.

Parameter	n=2	n=3	n=4	n=5	n=6	n=7	n=8
n.P							
n.I							
n.D							
n.OH							
n.OL							
n.MR							
n.H							
n.DR							
n.Pc							
n.Ic							
n.Dc							
n.Hc							
n.DB							
n.PO							
n.Oc							

Ten-segment Linearizer1 Parameters

Located in: Main menu = PYS1

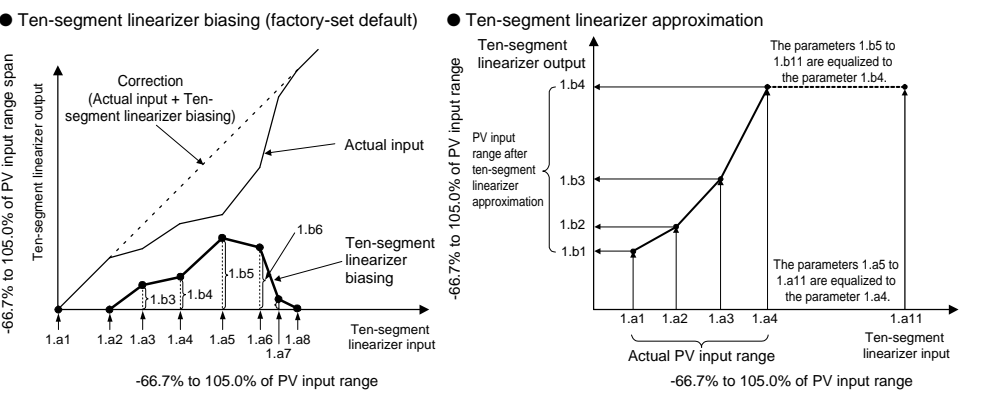

Parameter Symbol	Name of Parameter	Setting Range and Description	Initial Value	User Setting	Target Item in CD-ROM
1.a1	Ten-segment linearizer 1 input-1	-66.7% to 105.0% of PV input range	0.0% of PV input range	—	—
1.b1	Ten-segment linearizer 1	-66.7% to 105.0% of PV input range span -66.7% to 105.0% of PV input range when in ten-segment linearizer approximation	0.0% of PV input range span 0.0% of PV input range when in ten-segment linearizer approximation	—	—
1.a2	Ten-segment linearizer 1 input-2	-66.7% to 105.0% of PV input range	0.0% of PV input range	—	—
1.b2	Ten-segment linearizer 1	-66.7% to 105.0% of PV input range span -66.7% to 105.0% of PV input range when in ten-segment linearizer approximation	0.0% of PV input range span 0.0% of PV input range when in ten-segment linearizer approximation	—	—
1.a3	Ten-segment linearizer 1 input-3	-66.7% to 105.0% of PV input range	0.0% of PV input range	—	—
1.b3	Ten-segment linearizer 1	-66.7% to 105.0% of PV input range span -66.7% to 105.0% of PV input range when in ten-segment linearizer approximation	0.0% of PV input range span 0.0% of PV input range when in ten-segment linearizer approximation	—	—
1.a4	Ten-segment linearizer 1 input-4	-66.7% to 105.0% of PV input range	0.0% of PV input range	—	Ref.1.1(2)
1.b4	Ten-segment linearizer 1	-66.7% to 105.0% of PV input range span -66.7% to 105.0% of PV input range when in ten-segment linearizer approximation	0.0% of PV input range span 0.0% of PV input range when in ten-segment linearizer approximation	—	—
1.a5	Ten-segment linearizer 1 input-5	-66.7% to 105.0% of PV input range	0.0% of PV input range	—	—
1.b5	Ten-segment linearizer 1	-66.7% to 105.0% of PV input range span -66.7% to 105.0% of PV input range when in ten-segment linearizer approximation	0.0% of PV input range span 0.0% of PV input range when in ten-segment linearizer approximation	—	—
1.a6	Ten-segment linearizer 1 input-6	-66.7% to 105.0% of PV input range	0.0% of PV input range	—	—
1.b6	Ten-segment linearizer 1	-66.7% to 105.0% of PV input range span -66.7% to 105.0% of PV input range when in ten-segment linearizer approximation	0.0% of PV input range span 0.0% of PV input range when in ten-segment linearizer approximation	—	—
1.a7	Ten-segment linearizer 1 input-7	-66.7% to 105.0% of PV input range	0.0% of PV input range	—	—
1.b7	Ten-segment linearizer 1	-66.7% to 105.0% of PV input range span -66.7% to 105.0% of PV input range when in ten-segment linearizer approximation	0.0% of PV input range span 0.0% of PV input range when in ten-segment linearizer approximation	—	—

1.a8	Ten-segment linearizer 1 input-8	-66.7% to 105.0% of PV input range	0.0% of PV input range	—	—
1.b8	Ten-segment linearizer 1	-66.7% to 105.0% of PV input range span -66.7% to 105.0% of PV input range when in ten-segment linearizer approximation	0.0% of PV input range span 0.0% of PV input range when in ten-segment linearizer approximation	—	—
1.a9	Ten-segment linearizer 1 input-9	-66.7% to 105.0% of PV input range	0.0% of PV input range	—	—
1.b9	Ten-segment linearizer 1	-66.7% to 105.0% of PV input range span -66.7% to 105.0% of PV input range when in ten-segment linearizer approximation	0.0% of PV input range span 0.0% of PV input range when in ten-segment linearizer approximation	—	Ref.1.1(2)
1.a10	Ten-segment linearizer 1 input-10	-66.7% to 105.0% of PV input range	0.0% of PV input range	—	—
1.b10	Ten-segment linearizer 1	-66.7% to 105.0% of PV input range span -66.7% to 105.0% of PV input range when in ten-segment linearizer approximation	0.0% of PV input range span 0.0% of PV input range when in ten-segment linearizer approximation	—	—
1.a11	Ten-segment linearizer 1 input-11	-66.7% to 105.0% of PV input range	0.0% of PV input range	—	—
1.b11	Ten-segment linearizer 1	-66.7% to 105.0% of PV input range span -66.7% to 105.0% of PV input range when in ten-segment linearizer approximation	0.0% of PV input range span 0.0% of PV input range when in ten-segment linearizer approximation	—	—
1.PMD	Ten-segment linearizer 1 mode	0: Ten-segment linearizer biasing 1: Ten-segment linearizer approximation	0	—	—

Setup Parameters

Program Setpoint-related Parameters

Located in: Main menu = PARA ; Submenu = SP

Parameter Symbol	Name of Parameter	Setting Range and Description	Initial Value	User Setting	Target Item in CD-ROM
SPT	SP tracking selection	OFF, ON Tracking is performed when the mode changes from program to Local (The local setpoint keeps track of the program setpoint.)	OFF	—	Ref.5.2(3)
TMU	Program time unit	Sets the time unit of a program. hh:mm: "hour, minute" mm:ss: "minute, second"	hh:mm	—	—
SEG.T	Segment setting method	Defines the method of programming. Note that changing the setpoint of this parameter deletes the program in question. 0: Programming by setting segment times 1: Programming by setting segment ramps	0	—	Ref.5.1(1)
PT2.G	Program pattern-2 retransmission	The controller can serve as a program pattern generator. Thus, another program pattern can be created in addition to the control-purpose program pattern. Note that the segment time setpoints of the created program pattern are the same as those of the control-purpose program pattern. ON: used. OFF: Not used.	OFF	—	Ref.2.2(2)
PNC	Program pattern number clearance	The controller resets (clears) the program pattern number on the operating display to "0" at the end of program operation. OFF: Not cleared. ON: Cleared. (Set the program No. before restart program operation)	OFF	—	—
SPH1	Program setpoint-1 limiter upper limit	Place limits on the program setpoints when the controller is in program operation.	100.0% of PV input range	—	—
SPL1	Program setpoint-1 limiter lower limit	Place limits on the program setpoints when the controller is in program operation.	0.0% of PV input range	—	—
SPH2	Program setpoint-2 limiter upper limit	Place limits on the program setpoints when the controller is in program operation.	100.0% of PV input range	—	—
SPL2	Program setpoint-2 limiter lower limit	Place limits on the program setpoints when the controller is in program operation.	0.0% of PV input range	—	—

Alarm-related Parameters

Located in: Main menu = PARA ; Submenu = ALM

Parameter Symbol	Name of Parameter	Setting Range and Description	Initial Value	User Setting	Target Item in CD-ROM
PEH1	PV event 1 hysteresis	Allows margins to be set for a PV event setpoint. With the hysteresis settings, it is possible to prevent relays from chattering. 	0.5% of PV input range span	—	—
PEH2	PV event 2 hysteresis	—	—	—	—
PEH3	PV event 3 hysteresis	—	—	—	—
PEH4	PV event 4 hysteresis	—	—	—	Ref.3.4(3)
PEH5	PV event 5 hysteresis	—	—	—	Ref.3.4(5)
PEH6	PV event 6 hysteresis	0.0 to 100.0% of PV input range span	—	—	—
PEH7	PV event 7 hysteresis	—	—	—	—
PEH8	PV event 8 hysteresis	—	—	—	—
AL1	Instrument alarm-1 type	OFF, 1 to 20, 25 to 31 1: PV high limit (energized, no stand-by action) 2: PV low limit (energized, no stand-by action) 3: Deviation high limit (energized, no stand-by action) 4: Deviation low limit (energized, no stand-by action) 5: Deviation high limit (de-energized, no stand-by action) 6: Deviation low limit (de-energized, no stand-by action) For other alarm types, see "List of PV Event Types and Instrument Alarm Types" in Parameter Man Users Manual .	1	—	—
AL2	Instrument alarm-2 type	—	2	—	—
AL3	Instrument alarm-3 type	—	1	—	Ref.3.4(1)
AL4	Instrument alarm-4 type	—	2	—	—
HY1	Instrument alarm-1 hysteresis	0.0 to 100.0% of PV input range span Output alarm: 0.0 to 100.0%	0.5% of PV input range span	—	—
HY2	Instrument alarm-2 hysteresis	Allows margins to be set for an alarm setpoint. With the hysteresis settings, it is possible to prevent relays from chattering. 	0.5% of PV input range span Output alarm: 0.5%	—	Ref.3.4(3)
HY3	Instrument alarm-3 hysteresis	—	—	—	—
HY4	Instrument alarm-4 hysteresis	—	—	—	—
AMD	Alarm mode	Allows the instrument alarm function to be enabled or disabled according to the operating condition. 0: Always active 1: Not active when in RESET mode 2: Not active when in RESET mode or manual operation	0	—	Ref.3.4(2)

Control Action-related Parameters

Located in: Main menu = PARA ; Submenu = CTL

Parameter Symbol	Name of Parameter	Setting Range and Description	Initial Value	User Setting	Target Item in CD-ROM
OPR1	Output velocity limiter	OFF (0) 0.1 to 100.0%/sec Can limit control output velocity	OFF	—	—
MOD1	PID control mode	0: Standard PID control (with output bump at SP change) 1: Fixed-point control (without output bump at SP change) Choose "Fixed-point Control" when controlling pressure or flow rate. AUTO (0), 50.0 to 200.0% The larger Setting, the sooner PID computation (integral computation) stops. Used when the control output travels up to 100% or down to 0% and stays at this point.	0	—	Ref.2.1(2)
AR1	Anti-risetime wrapup (Excess integration prevention)	AUTO (0), 50.0 to 200.0% The larger Setting, the sooner PID computation (integral computation) stops. Used when the control output travels up to 100% or down to 0% and stays at this point.	AUTO	—	Ref.2.1(4)
ZON	Zone PID selection	0: Segment PID 1: Zone PID If set to "Segment PID," allows PID constants to be selected for each segment. If set to "Zone PID," automatically selects PID constants according to the temperature range set in the given Reference Point parameter.	1	—	Ref.5.1(2)
R.MD	Restart mode	CONT: Continues action set before power failure. MAN: Starts from manual operation status RESET: Continues action set before power failure and starts computation from the preset output value.	CONT	—	—

R.TM	Restart timer	0 to 10 sec. Sets time between power on and the instant where controller starts computation.	0 sec.	—	—
GRP	PID group number	Allows you to determine how many groups of setpoint, alarm and PID parameters the controller should show. 1: Show one set. 2: Show two sets. 3: Show three sets. 4: Show four sets. 5 to 8: Show as many groups of parameters as have been set.	8	—	—
1.RP1	Zone PID reference point-1	0.0 to 100.0% of PV input range. Note that 1.RP1 ≤ 2.RP1 ≤ 4.RP1 ≤ 5.RP1 ≤ 6.RP1. Sets reference points at which switching is carried out between groups of PID constants according to the given temperature zone. You can set a maximum of six reference points and therefore a maximum of seven temperature zones.	100.0% of PV input range	—	—
2.RP1	Zone PID reference point-2	—	—	—	—
3.RP1	Zone PID reference point-3	The example			

Security-related Parameters

Located in: Main menu = CMLP ; Submenu = LOCK

Parameter Symbol	Name of Parameter	Setting Range and Description	Initial Value	User Setting	Target Item in CD-ROM
▼/▲	Locking of front panel up/down keys (▲ and ▼)	OFF: Unlock ON: Lock	OFF		
PT.No	Locking of front panel PT.No key	OFF: Unlock ON: Lock	OFF		
RUN	Locking of front panel RUN key	OFF: Unlock ON: Lock	OFF		
MODE	Locking of front panel MODE key	OFF: Unlock ON: Lock	OFF		
PROG	Locking of operating parameter main menu PROG display	OFF: Unlock ON: Lock	OFF		
LP1	Operating parameter main menu [LP1] lock	OFF: Unlock ON: Lock	OFF		Ref.7.1(2)
LP2	Although not used in single-loop control, it is shown on the display.				
PID	Operating parameter submenu [PID] lock	OFF: Unlock ON: Lock	OFF		
USR	Although not used in single-loop control, it is shown on the display.				
PYS1	Operating parameter main menu [PYS1] lock	OFF: Unlock ON: Lock	OFF		
PYS2	Although not used in single-loop control, it is shown on the display.				
PWD	Password setting	0: Password not set 1 to 30000 Note: If a password is set, the setup parameters cannot be displayed without entering the correct password.	0		Ref.7.1(1)

SELECT Display Parameters

Located in: Main menu = CONF ; Submenu = CSEL

Parameter Symbol	Name of Parameter	Setting Range and Description	Initial Value	User Setting	Target Item in CD-ROM
C.S1	SELECT display-1 registration	OFF, 101 to 1023 Select the desired parameter from among the operating and setup parameters, then register the number (D register No.) accompanying that parameter.	OFF		
C.S2	SELECT display-2 registration	For example, registering "231" for C.S1 allows you to change instrument alarm-1 setpoint in operating display. Numbers for registering instrument alarm SP parameter for operating display: Instrument alarm-1 setpoint: 231 Instrument alarm-2 setpoint: 232 Instrument alarm-3 setpoint: 233 Instrument alarm-4 setpoint: 234			Ref.6.1(1)
C.S3	SELECT display-3 registration				
C.S4	SELECT display-4 registration				
C.S5	SELECT display-5 registration				

Contact Output Registration Parameters

Located in: Main menu = CONF ; Submenu = DO

Parameter Symbol	Name of Parameter	Setting Range and Description	Initial Value	User Setting	Target Item in CD-ROM
DO1	Relay output flag registration for DO1	The following setpoints are registration numbers for single-loop control only. 5705: PV event 1 output 5706: PV event 2 output 5689: Instrument alarm 1 output 5129: Time event 1 output 5130: Time event 2 output 5131: Time event 3 output 5133: Time event 4 output	5705		
DO2	Relay output flag registration for DO2	0: No function	5706		
DO3	Relay output flag registration for DO3		5689		
DO4	Open-collector transistor output flag registration for DO4		5129		
DO5	Open-collector transistor output flag registration for DO5	See "External contact output" in "6. Terminal Wiring Diagrams," of Installation User's Manual .	5130		Ref.3.2(2)
DO6	Open-collector transistor output flag registration for DO6		5131		
DO7	Open-collector transistor output flag registration for DO7		5133		

Contact Input Registration Parameters

Located in: Main menu = CONF ; Submenu = DI

Parameter Symbol	Name of Parameter	Setting Range and Description	Initial Value	User Setting	Target Item in CD-ROM																																								
PROG	Start of program operation (When "Din" changes from OFF to ON)	These parameters determine which contact input to use to make selections/switches listed on the left. D1: 5161 No function: 0	5165																																										
RST	Stop of program operation (When "Din" changes from OFF to ON)	D2: 5162 D3: 5163 D4: 5164 D5: 5165 D6: 5166 D7: 5167 D8: 5168	5166																																										
LOC	Start of local-mode operation (When "Din" changes from OFF to ON)		5167																																										
HOLD	Start of hold-mode operation (When "Din" changes from OFF to ON)	The contact inputs are factory-set as shown below. Contact inputs 1 to 4 (D1 to D4): Program pattern number selection (see below)	0																																										
ADV	Advance of segment (When "Din" changes from OFF to ON)	Contact input 5 (D5): Start of program operation Contact input 6 (D6): Stop of program operation Contact input 7 (D7): Start of local-mode operation Contact input 8 (D8): ON when using 16 or more of program patterns	0																																										
A/M1	Loop-1 AUTOMAN switching (AUTO when contact input is ON; MAN when contact input is OFF)		0																																										
A/M2	Loop-2 AUTOMAN switching	Program pattern number selection	0																																										
L/C	LOCAL/CASCADE switching Not used for single-loop control.		0		Ref.3.1(7)																																								
PTN.0	Bit 0 of program pattern number	<table border="1"> <tr><td>1</td><td>2</td><td>3</td><td>4</td><td>5</td><td>6</td><td>7</td><td>8</td></tr> <tr><td>D1</td><td>ON</td><td>OFF</td><td>ON</td><td>OFF</td><td>ON</td><td>OFF</td><td>ON</td></tr> <tr><td>D2</td><td>OFF</td><td>ON</td><td>ON</td><td>OFF</td><td>OFF</td><td>ON</td><td>ON</td></tr> <tr><td>D3</td><td>OFF</td><td>OFF</td><td>OFF</td><td>ON</td><td>ON</td><td>ON</td><td>OFF</td></tr> <tr><td>D4</td><td>OFF</td><td>OFF</td><td>OFF</td><td>OFF</td><td>OFF</td><td>OFF</td><td>ON</td></tr> </table>	1	2	3	4	5	6	7	8	D1	ON	OFF	ON	OFF	ON	OFF	ON	D2	OFF	ON	ON	OFF	OFF	ON	ON	D3	OFF	OFF	OFF	ON	ON	ON	OFF	D4	OFF	OFF	OFF	OFF	OFF	OFF	ON	5161		
1	2	3	4	5	6	7	8																																						
D1	ON	OFF	ON	OFF	ON	OFF	ON																																						
D2	OFF	ON	ON	OFF	OFF	ON	ON																																						
D3	OFF	OFF	OFF	ON	ON	ON	OFF																																						
D4	OFF	OFF	OFF	OFF	OFF	OFF	ON																																						
PTN.1	Bit 1 of program pattern number	<table border="1"> <tr><td>9</td><td>10</td><td>11</td><td>12</td><td>13</td><td>14</td><td>15</td></tr> <tr><td>D1</td><td>ON</td><td>OFF</td><td>ON</td><td>OFF</td><td>ON</td><td>OFF</td></tr> <tr><td>D2</td><td>OFF</td><td>ON</td><td>ON</td><td>OFF</td><td>OFF</td><td>ON</td></tr> <tr><td>D3</td><td>OFF</td><td>OFF</td><td>OFF</td><td>ON</td><td>ON</td><td>ON</td></tr> <tr><td>D4</td><td>ON</td><td>ON</td><td>ON</td><td>ON</td><td>ON</td><td>ON</td></tr> </table>	9	10	11	12	13	14	15	D1	ON	OFF	ON	OFF	ON	OFF	D2	OFF	ON	ON	OFF	OFF	ON	D3	OFF	OFF	OFF	ON	ON	ON	D4	ON	ON	ON	ON	ON	ON	5162							
9	10	11	12	13	14	15																																							
D1	ON	OFF	ON	OFF	ON	OFF																																							
D2	OFF	ON	ON	OFF	OFF	ON																																							
D3	OFF	OFF	OFF	ON	ON	ON																																							
D4	ON	ON	ON	ON	ON	ON																																							
PTN.2	Bit 2 of program pattern number	<table border="1"> <tr><td>D1</td><td>ON</td><td>OFF</td><td>ON</td><td>OFF</td><td>ON</td><td>OFF</td></tr> <tr><td>D2</td><td>OFF</td><td>ON</td><td>ON</td><td>OFF</td><td>OFF</td><td>ON</td></tr> <tr><td>D3</td><td>OFF</td><td>OFF</td><td>OFF</td><td>ON</td><td>ON</td><td>ON</td></tr> <tr><td>D4</td><td>ON</td><td>ON</td><td>ON</td><td>ON</td><td>ON</td><td>ON</td></tr> </table>	D1	ON	OFF	ON	OFF	ON	OFF	D2	OFF	ON	ON	OFF	OFF	ON	D3	OFF	OFF	OFF	ON	ON	ON	D4	ON	ON	ON	ON	ON	ON	5163														
D1	ON	OFF	ON	OFF	ON	OFF																																							
D2	OFF	ON	ON	OFF	OFF	ON																																							
D3	OFF	OFF	OFF	ON	ON	ON																																							
D4	ON	ON	ON	ON	ON	ON																																							
PTN.3	Bit 3 of program pattern number	<table border="1"> <tr><td>D1</td><td>ON</td><td>OFF</td><td>ON</td><td>OFF</td><td>ON</td><td>OFF</td></tr> <tr><td>D2</td><td>OFF</td><td>ON</td><td>ON</td><td>OFF</td><td>OFF</td><td>ON</td></tr> <tr><td>D3</td><td>OFF</td><td>OFF</td><td>OFF</td><td>ON</td><td>ON</td><td>ON</td></tr> <tr><td>D4</td><td>ON</td><td>ON</td><td>ON</td><td>ON</td><td>ON</td><td>ON</td></tr> </table>	D1	ON	OFF	ON	OFF	ON	OFF	D2	OFF	ON	ON	OFF	OFF	ON	D3	OFF	OFF	OFF	ON	ON	ON	D4	ON	ON	ON	ON	ON	ON	5164														
D1	ON	OFF	ON	OFF	ON	OFF																																							
D2	OFF	ON	ON	OFF	OFF	ON																																							
D3	OFF	OFF	OFF	ON	ON	ON																																							
D4	ON	ON	ON	ON	ON	ON																																							
PTN.4	Bit 4 of program pattern number	<table border="1"> <tr><td>D1</td><td>ON</td><td>OFF</td><td>ON</td><td>OFF</td><td>ON</td><td>OFF</td></tr> <tr><td>D2</td><td>OFF</td><td>ON</td><td>ON</td><td>OFF</td><td>OFF</td><td>ON</td></tr> <tr><td>D3</td><td>OFF</td><td>OFF</td><td>OFF</td><td>ON</td><td>ON</td><td>ON</td></tr> <tr><td>D4</td><td>ON</td><td>ON</td><td>ON</td><td>ON</td><td>ON</td><td>ON</td></tr> </table>	D1	ON	OFF	ON	OFF	ON	OFF	D2	OFF	ON	ON	OFF	OFF	ON	D3	OFF	OFF	OFF	ON	ON	ON	D4	ON	ON	ON	ON	ON	ON	5168														
D1	ON	OFF	ON	OFF	ON	OFF																																							
D2	OFF	ON	ON	OFF	OFF	ON																																							
D3	OFF	OFF	OFF	ON	ON	ON																																							
D4	ON	ON	ON	ON	ON	ON																																							
MG1	Interruptive message display 1	See "External contact input" in "6. Terminal Wiring Diagrams," of Installation User's Manual .	0																																										
MG2	Interruptive message display 2		0																																										
MG3	Interruptive message display 3		0																																										
MG4	Interruptive message display 4		0																																										

UP Mode Parameters

Located in: Main menu = UPMD ; Submenu = MD

Parameter Symbol	Name of Parameter	Setting Range and Description	Initial Value	User Setting	Target Item in CD-ROM
UPM	Controller mode (UP mode)	1: Single-loop control For another Controller mode, see User's Manual (Reference) (CD-ROM version).	1		—
SMP	PV sampling period setting	100, 200 and 500 ms The controller restarts if any change is made to the PV sampling period; this does not affect other parameter settings at all, however.	200 ms		Ref.1.1(4)
SMEC	Sampling period error counter (reading only)	0 to 30000	Shows 0 at power-on.		Ref.1.1(5)

Input-related Parameters

Located in: Main menu = UPMD ; Submenu = IN

Parameter Symbol	Name of Parameter	Setting Range and Description	Initial Value	User Setting	Target Item in CD-ROM
IN1	PV input type (INPUT 1 terminals Terminals ①, ② and ③)	Specify the type of PV input as a range code. See "Instrument Input Range Codes" in Initial Settings User's Manual .	OFF		—
UNI1	PV input unit	Select the unit of PV input. %: Percent °F: Fahrenheit °C: Degree Celsius -: No unit	Depends on the PV input type.		—
RH1	Max. value of PV input range	Set the PV input range (RL1 < RH1).	Depends on the PV input type.		—
RL1	Min. value of PV input range	- For temperature input - Set the range of temperature that is actually controlled. - For voltage input - Set the range of a voltage signal that is applied. The scale across which the voltage signal is actually controlled should be set using the parameters Maximum Value of PV Input Scale (SH1) and Minimum Value of PV Input Scale (SL1).	—		—
SDP1	PV input decimal point position (shown when in voltage-input mode)	Set the position of the decimal point of voltage-mode PV input. 0 to 4. 0: No decimal place, 1: One decimal place, 2 to 4: Two, three, four decimal places	Depends on the PV input type.		—
SH1	Max. value of PV input scale (shown when in voltage-input mode)	Set the read-out scale of voltage-mode PV input. -19999 to 30000, where SL1 < SH1, SH1 - SL1 ≤ 30000	Depends on the PV input type.		—
SL1	Min. value of PV input scale (shown when in voltage-input mode)		—		—
BSL1	Selection of PV input burnout action	Allows the PV input value to be determined as shown below in case of PV input burnout. • 105% of PV input range if set to "Upscale" • -5.0% of PV input range if set to "Downscale" OFF: Disable UP: Upscale DOWN: Downscale	Depends on the PV input type.		—
RJC1	Presence/absence of PV input reference junction compensation	Allows input compensation to be applied to thermocouple input. OFF: Absent ON: Present	ON		—
IN3	Auxiliary analog input type (INPUT 3 terminals Terminals ④ and ⑤)	Although not used in single-loop control, it is shown on the display.			—
UNI3	Auxiliary analog input unit	Although not used in single-loop control, it is shown on the display.			—
RH3	Maximum value of auxiliary analog input range	Although not used in single-loop control, it is shown on the display.			—
RL3	Minimum value of auxiliary analog input range	Although not used in single-loop control, it is shown on the display.			—
SDP3	Auxiliary analog input decimal point position	Although not used in single-loop control, it is shown on the display.			—
SH3	Max. value of auxiliary analog input scale	Although not used in single-loop control, it is shown on the display.			—
SL3	Min. value of auxiliary analog input scale	Although not used in single-loop control, it is shown on the display.			—
BSL3	Auxiliary analog input burnout action selection	Although not used in single-loop control, it is shown on the display.			—
P.UN1	PV unit	Set the unit of PV. %: Percent °F: Fahrenheit °C: Degree Celsius -: No unit	Same as the unit of PV input		—
P.DP1	PV decimal point position	Under normal operation, set the same value as in the PV Input Decimal Point Position (SDP1) parameter. To shift the decimal point for temperature input, use this parameter. For example, set as "P.DP1 = 0" to change a temperature reading of one decimal place to that of no decimal places. This involves reconfiguring the P.RH1 and P.RL1 parameters. 0 to 4	—		Ref.1.1(8)
P.RH1	Maximum value of PV range	Under normal operation, keep the values of these parameters between the maximum and minimum values of the PV input range. -19999 to 30000	Maximum value of PV input range or scale		—
P.RL1	Minimum value of PV range	P.RL1 < P.RH1, where P.RH1 - P.RL1 = 30000	Minimum value of PV input range or scale		—

Output-related Parameters

Located in: Main menu = UPMD ; Submenu = OUT

Parameter Symbol	Name of Parameter	Setting Range and Description	Initial Value	User Setting	Target Item in CD-ROM
OT1	Control output type	0 Time proportional PID relay contact output (terminals ①-②-③) 1 Time proportional PID voltage pulse output (terminals ④-⑤) 2 Current output (terminals ⑥-⑦) 3 ON/OFF control relay contact output (terminals ①-②-③) The following 4 to 12 are displayed only for heating/cooling type controllers. 4 Heating-side relay output (terminals ①-②-③), cooling-side relay output (terminals ④-⑤-⑥) 5 Heating-side pulse output (terminals ⑥-⑦), cooling-side relay output (terminals ⑧-⑨-⑩) 6 Heating-side current output (terminals ⑥-⑦), cooling-side relay output (terminals ⑧-⑨-⑩) 7 Heating-side relay output (terminals ①-②-③), cooling-side pulse output (terminals ④-⑤-⑥) 8 Heating-side pulse output (terminals ⑥-⑦), cooling-side pulse output (terminals ⑧-⑨-⑩) 9 Heating-side current output (terminals ⑥-⑦), cooling-side pulse output (terminals ⑧-⑨-⑩) 10 Heating-side relay output (terminals ①-②-③), cooling-side current output (terminals ④-⑤-⑥) 11 Heating-side pulse output (terminals ⑥-⑦), cooling-side current output (terminals ⑧-⑨-⑩) 12 Heating-side current output (terminals ⑥-⑦), cooling-side current output (terminals ⑧-⑨-⑩)	0 Heating/cooling type: 4		—
CT1	Control output cycle time Heating-side control output cycle time in heating/cooling control	1 to 1000 sec. Relay's Behavior when Cycle Time = 10 sec. For 20% of Control Output For 50% of Control Output For 80% of Control Output On-state duration: 2 sec, Off-state duration: 8 sec. On-state duration: 5 sec, Off-state duration: 5 sec. On-state duration: 8 sec, Off-state duration: 2 sec.	30 sec.		—
CTc1	Cooling-side control output cycle time	1 to 1000 sec.	30 sec.		—
AO1	Analog output-1 type (OUTPUT 1: Terminals ④ and ⑤)	Allows control output or retransmission output to be presented as one of the following current signals. 0: 4 to 20 mA	0		—
AO2	Analog output-2 type (OUTPUT 2: Terminals ⑥ and ⑦)	1: 0 to 20 mA 2: 20 to 4 mA 3: 20 to 0 mA	0		—
AO3	Analog output-3 type (OUTPUT 3: Terminals ⑧ and ⑨)		0		—
A1H	Analog output-1 100% segmental point	Set the values of segmental points for the 0% and 100% output levels at which the values are presented via OUTPUT-1 (terminals ④ and ⑤). See "Performing Split Computations" below.	100.0 %		Ref.2.1(7)
A1L	Analog output-1 0% segmental point	-5.0% to 105.0%, where A1L < A1H	0.0 %		—
A2H	Analog output-2 100% segmental point	Set the values of segmental points for the 0% and 100% output levels at which the values are presented via OUTPUT-2 (terminals ⑥ and ⑦). See "Performing Split Computations" below.	100.0 %		—
A2L	Analog output-2 0% segmental point	-5.0% to 105.0%, where A2L < A2H	0.0 %		—
A3H	Analog output-3 100% segmental point	Set the values of segmental points for the 0% and 100% output levels at which the values are presented via OUTPUT-3 (terminals ⑧ and ⑨). See "Performing Split Computations" below.	100.0 %		—
A3L	Analog output-3 0% segmental point	-5.0% to 105.0%, where A3L < A3H	0.0 %		—

Performing Split Computations

V-mode Output

The following explains an example of letting "Analog OUTPUT-1 (terminals ④ and ⑤)" and "Analog OUTPUT-3 (terminals ⑧ and ⑨)" present the V-mode characteristics of split computations.
[1] Set the Control Output Type (OT1) parameter to "2".
This sets the control output to "current output."
[2] Set the Retransmission Output1 (RET1) parameter to "3".
This sets the retransmission output to "control output retransmission."
[3] Set the Analog Output-1 100% Segmental Point (A1H) parameter to "100%".
[4] Set the Analog Output-1 0% Segmental Point (A1L) parameter to "25%".
[5] Set the Analog Output-3 100% Segmental Point (A3H) parameter to "0%".
[6] Set the Analog Output-3 0% Segmental Point (A3L) parameter to "75%".

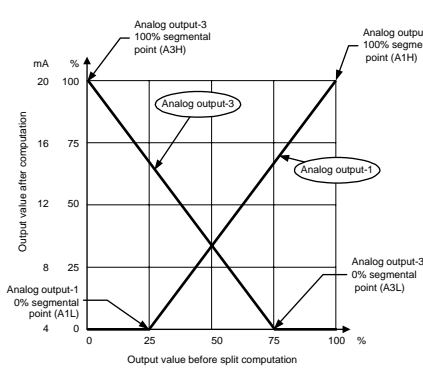

The figure on the right shows an example where both analog outputs-1 and 3 are set to the current signal of 4 to 20 mA DC. The type of output signal can be determined separately for each of the analog outputs listed above, using the following three parameters.

Analog output-1: Analog output-1 type (AO1)
Analog output-2: Analog output-2 type (AO2)
Analog output-3: Analog output-3 type (AO3)

Parallel-mode Output

The following explains an example of letting "Analog OUTPUT-1 (terminals ④ and ⑤)" and "Analog OUTPUT-3 (terminals ⑧ and ⑨)" present the parallel-mode characteristics of split computations.
[1] Set the Control Output Type (OT1) parameter to "2".
This sets the control output to "current output."
[2] Set the Retransmission Output1 (RET1) parameter to "3".
This sets the retransmission output to "control output retransmission."
[3] Set the Analog Output-1 100% Segmental Point (A1H) parameter to "100%".
[4] Set the Analog Output-1 0% Segmental Point (A1L) parameter to "25%".
[5] Set the Analog Output-3 100% Segmental Point (A3H) parameter to "75%".
[6] Set the Analog Output-3 0% Segmental Point (A3L) parameter to "0%".

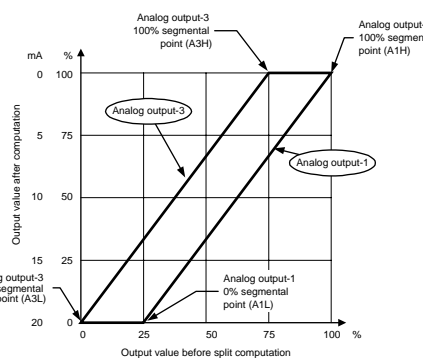

The figure on the right shows an example where both analog outputs-1 and 3 are set to the current signal of 20 to 0 mA DC. The type of output signal can be determined separately for each of the analog outputs listed above, using the following three parameters.

Analog output-1: Analog output-1 type (AO1)
Analog output-2: Analog output-2 type (AO2)
Analog output-3: Analog output-3 type (AO3)

Communication Parameters

Located in: Main menu = UPMD ; Submenu = R485

Parameter Symbol	Name of Parameter	Setting Range and Description	Initial Value	User Setting	Target Item in CD-ROM
PSL1	Protocol selection	0: PC link communication 1: PC link communication (with sum check) 2: Ladder communication 3: Coordinated master station 7: MODBUS (ASCII) 8: MODBUS (RTU)	0		—
BPS1	Baud rate	600, 1200, 2400, 4800, 9600 (bps)	9600		—
PR11	Parity	NONE: None EVEN: Even ODD: Odd	EVEN		Communication Function
STP1	Stop bit	1, 2	1		—
DLN1	Data length	7, 8; 7 is fixed for MODBUS (ASCII), Ladder 8 is fixed for MODBUS (RTU).	8		—
ADR1	Address	1 to 99 However, the maximum number of stations connectable is 31.	1		—
RP.T1	Minimum response time	0 to 10 (x 10 ms)	0		—

Valve Calibration-related Parameters (Displayed for Position Proportional Controllers)

Located in: Main menu = UPMD ; Submenu = VALV

Parameter Symbol	Name of Parameter	Setting Range and Description	Initial Value	User Setting	Target Item in CD-ROM
V.AT	Valve auto tuning	Automatically adjusts the fully-closed and fully-opened positions of a valve. When this function is used, there is no need for adjustment using the parameters V.RS, V.L and V.H.	OFF		—
V.RS	Valve position setting reset	The parameters V.RS, V.L and V.H are designed for manual adjustment of valve positions. Setting V.RS to 1 resets the valve adjustment settings and causes the indication "V.RS" to blink.	0		—
V.L	Fully-closed valve position setting	Pressing the SET/ENT key with valve position set to the fully-closed position causes the adjusted value to be stored.	Undefined		—
V.H	Fully-opened valve position setting	Pressing the SET/ENT key with valve position set to the fully-opened position causes the adjusted value to be stored. When V.H adjustment is complete, V.H stops blinking.	Undefined		—
TR.T	Valve traveling time	5 to 300 sec. Used to operate a valve according to the estimated valve position. Set the time required for the valve to open fully from a state of being fully closed. Confirm the valve traveling time by consulting the datasheet of the valve's specifications. The valve traveling time is only effective when Valve Adjustment Mode (V.MD) is set to 1 or 2.	60 sec.		—
V.MOD	Valve adjusting mode	0: Valve position feedback type 1: Valve position feedback type (moves to the estimating type if a feedback input error or burnout occurs.) 2: Valve position estimating type	0		—

Parameter-initializing Parameters

Located in: Main menu = UPMD ; Submenu = INIT

Parameter Symbol	Name of Parameter	Setting Range and Description	Initial Value	User Setting	Target Item in CD-ROM
INI	Parameter initialization	OFF: - ON: Initialize parameters	OFF		—

Tips about Heating/Cooling Control (for heating/cooling controllers only)

In heating/cooling control, the controller outputs the result of computation after splitting it into heating-purpose and cooling-purpose signals. In addition, the controller can perform PID control or ON/OFF control on the heating and cooling sides separately. When performing ON/OFF control, set the proportional band to "0". The controller splits the result of computation (0 to 100%) into heating-side and cooling-side signals, as described below.